

RC SUMO ROBOT COMPETITION

1. OBJECTIVE

Participants are required to build a self-contained mobile robot that is able to push its opponent out of the specified ring in according to the tournament rules. Robot handlers are to operate their robots through the radio-controlled console.

2. ROBOT SPECIFICATIONS

2.1 Dimensions and Weight

The size of the robots shall not exceed 20cm (length) x 20cm (width). There is no height restriction and it may take any shape and size once the match begins.

The weight shall not exceed 3 kg excluding the radio-controlled console used by the robot handler.

2.2 Don'ts in the Design

2.2.1 Do not disturb the opponent's radio-control by putting a jamming device in the robot.

2.2.2 Robots shall not damage the arena deliberately.

2.2.3 Robots shall not throw liquid or powder or other substances at the opponent.

2.2.4 Robots shall not employ any flammable devices as a weapon.

2.2.5 Robots should not secure itself on the ring surface by using, suction cups, diaphragms, sticky treads, glue or other such devices.

2.2.6 Projectile weapons or saw-blades are prohibited.

2.3 Radio-controlled Frequencies

2.3.1 The radio-controlled frequencies shall only be FM 27 MHz or 2.4GHz Digital Spectrum Modulation (DSM).

2.3.2 Participants who are using FM 27MHz must be capable of operating in any of its frequency bands. Participants are allowed up to two changes in frequency bands in a game. If the robot failed to proceed after the second band change, it shall be retired from the game.

2.4 Labelling

All robots must be labeled with of their team names on the front of the robot. The minimum font size is Arial 24.

2.5 Clearing of Debris

Fallen items from the robots shall be removed after each match.

3. RING SPECIFICATIONS (REFER TO FIGURE 1)

3.1 Dimensions and Materials

The ring arena is made of a single ½" MDF board and covered by a 3mm black hard rubber sheet. The diameter of the ring is 154cm including the boundary marking.

3.2 Markings

Two red-brown color starting lines (20cm x 2cm) locate at 20cm apart at the centre of the ring. They indicate the starting positions for two competing robots.

The boundary of the ring arena is marked in white color. The width is 5cm.

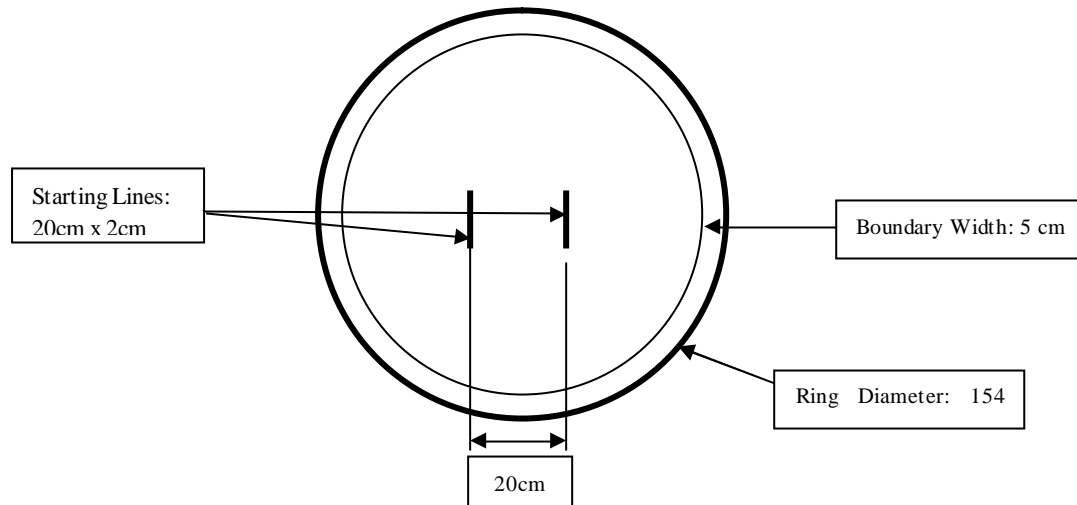

4. GAMES RULES

4.1 Sumo Game

The tournament shall divide the participating teams into groups of maximum 4 robots.

A game consists of 3 matches. Each match shall last for 2 minutes. One point shall be given to every match winner. Zero point shall be given to a draw or a loser.

If a game ends with no winner, a test of strength by the two robots immediately after the last match will be the decider.

4.2 Match Winner

A robot wins when any part of the opponent robot touches the floor.

4.3 Service Time

Participants will be given one minute of Servicing -Time before the start of their game. A maximum of two members are allowed to service their robots at a designated area under supervision. Only replacement of identical parts and batteries are allowed during the Servicing-Time.

4.4 Time Out

Each team will only be given one time-out of one minute within a game (of 3 matches). The time-out will apply after the match and only for the requesting team. Changing of battery is not allowed during the time-out.

4.5 Robot Handler

A participant is allowed to handle only one same robot throughout the event. Each robot should only have one same handler. The handler and robot will be identified during registration and caging.

5. CAGING

Robots shall be inspected and caged at least 1 hour before the start of the game.