

# AUTONOMOUS ROBOT SUMO COMPETITION

## 1. OBJECTIVE

Participants are required to build an **autonomous**, self-contained mobile robot that is able to push its opponent out of the specified ring according to the tournament rules. Robot handlers are to start the robot with the press of a single button.

## 2. ROBOT SPECIFICATIONS

### 2.1 Dimensions and Weight

The size of the robots shall not exceed 20cm (length) x 20cm (width). There is no height restriction and it may take any shape and size once the match begins.

The weight of the robot shall not exceed 3 kg.

### 2.2 Restrictions on robot Design

2.2.1 The robot must not have a device that interferes with the sensor operation of its opponent. e.g. Jammer, strobe light, laser & etc.

2.2.2 Robots shall not damage the arena deliberately.

2.2.3 Robots shall not throw liquid or powder or other substances at the opponent.

2.2.4 Robots shall not employ any flammable devices as a weapon.

2.2.5 Robots should not secure itself on the ring surface by using, suction cups, diaphragms, sticky treads, glue or other such devices.

2.2.6 Projectile weapons or saw-blades are prohibited.

### 2.3 Robot Control

The robot shall be autonomous. No external form of control or any external intervention is allowed. The Robot is to be started with a single Toggle-type switch.

### 2.4 Labelling

All robots must be labeled with their team names on the front of the robot. The minimum font size is Arial 24.

### 2.5 Clearing of Debris

Fallen items from the robots shall be removed after each match.

## 3. RING SPECIFICATIONS (REFER TO FIGURE 1)

### 3.1 Dimensions and Materials

The ring arena is made of a single ½” MDF board and covered by a 3mm black hard rubber sheet. The diameter of the ring is 154cm including the boundary marking.

### 3.2 Markings

Two red-brown color starting lines (20cm x 2cm) locate at 20cm apart at the centre. They indicate the starting positions for two competing robots.

The boundary of the ring arena is marked in white color. The width is 5cm.

### 3.3 Ring Condition

The ring condition may vary slightly and participants should design and build their robots with robustness in mind.

## 4. GAMES RULES

### 4.1 Sumo Game

The tournament shall divide the participating teams into groups of maximum 4 robots.

A game consists of 3 matches. Each match shall last for 2 minutes. One point shall be given to every match winner. Zero point shall be given to a draw or a loser.

If a game ends with no winner, a test of strength by the two robots immediately after the last match will be the decider.

#### 4.2 Match Winner

A robot wins when any part of the opponent robot touches the floor.

#### 4.3 Service Time

Participants will be given 1 minute of Servicing-Time before the start of their game. A maximum of two members are allowed to service their robots at a designated area under supervision. Only replacement of identical parts and batteries are allowed during the Servicing-Time.

#### 4.4 Time Out

Each team will only be given one time-out of one minute in a game (of 3 matches). The time-out will apply after the match and only for the requesting team. Changing of battery is not allowed during the time-out.

#### 4.5 Robot Handler

A participant is allowed to handle only one same robot throughout the event. Each robot should only have one same handler. The handler and robot will be identified during the registration and caging.

### 5. CAGING

Robots shall be inspected and caged at least 1 hour before the start of the game.

### 6. CLONING:

- 6.1 In accordance with the spirit of the competition, clones will be identified during the "caging" procedure and shall be grouped to fight against each other during the preliminary stages.
- 6.2 Clones are robots with substantially identical physical appearance and working principles.
- 6.3 When in doubt, the decision of the Judges will be final.

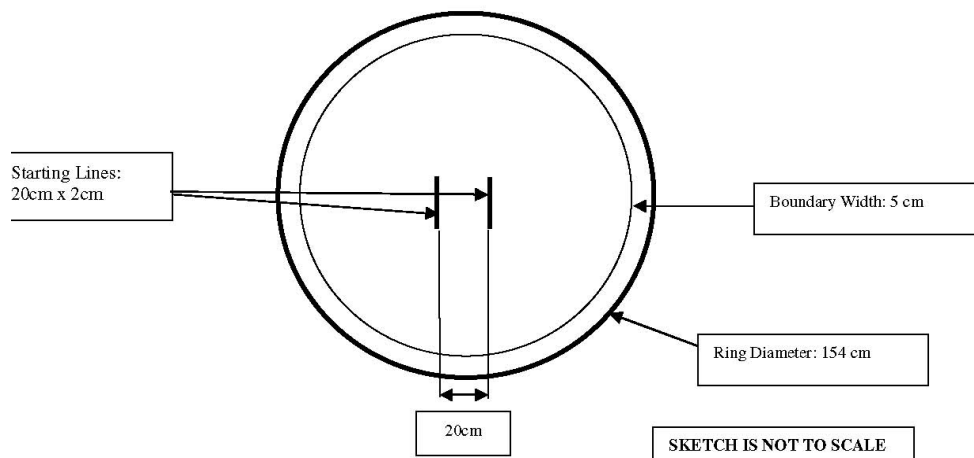

Figure 1

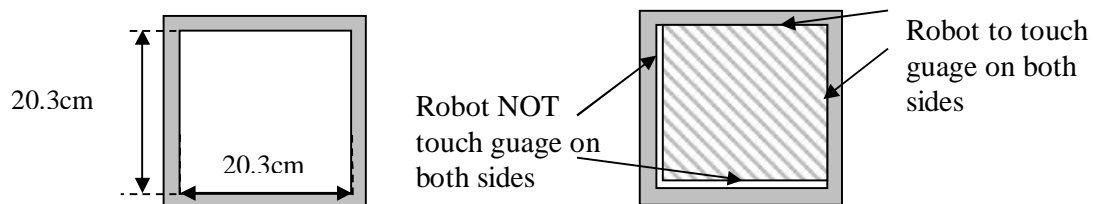

Figure 2: Caging Gauge