

ROBOT COLONY COMPETITION

1. OBJECTIVE

The objective of the competition is to build a self-contained autonomous cooperative pair of mobile robots that are able to search out and detect coloured pellets which must be collected and deposited at a designated pocket for each colour. 2 different coloured pellets are available for collection on the platform. The goal is to collect and deposit equal number of the 2 different colored pellets. Points will be awarded for correctly deposited pellets and deducted for wrongly deposited pellets. Points will also be deducted for unequal number of the 2 different colored pellets deposited. The performance of each team is decided, at the end of the run time of 5 mins, by the total points accumulated. In the event that all pellets are delivered to their designated pockets before the run time of 5 mins has expired, then the shortest time taken will be considered as a further score.

2. SPECIFICATIONS FOR PLATFORM

2.1 The platform will cover a square area of dimensions 2.3m x 2.3m as shown in Fig 1. There are no walls bordering the platform.

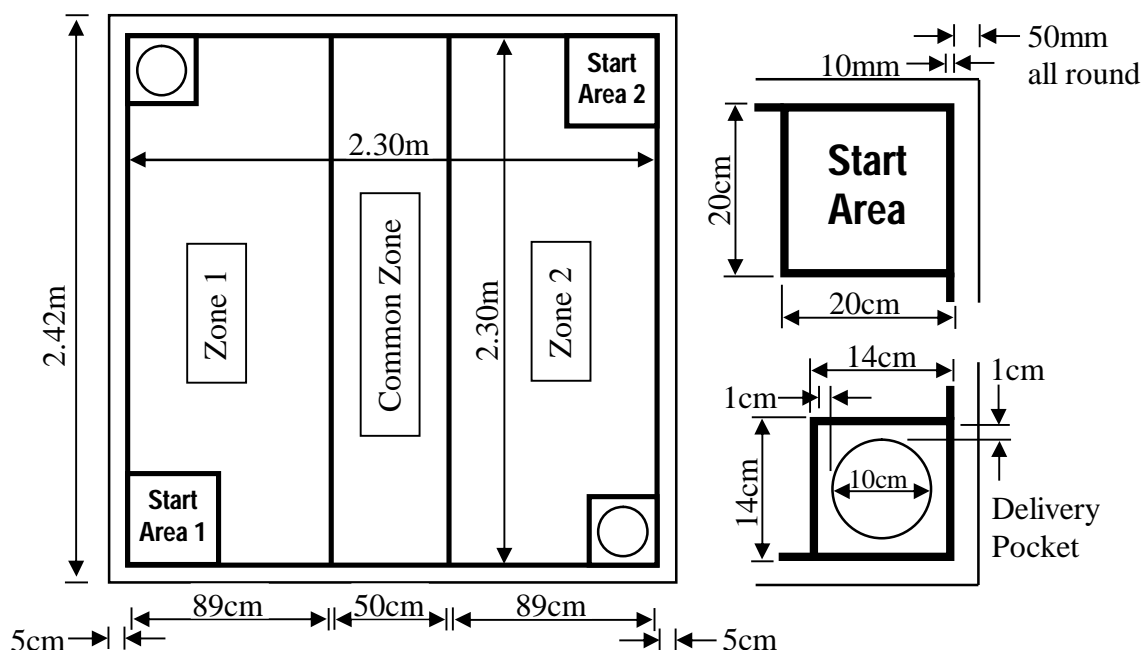

Figure 1 Robot Colony Platform

2.2 The starting locations for the 2 robots must be at the 2 Start Areas. Delivery pockets shall be located at the 2 opposite corners. The color for each designated delivery area will be decided by the judges during the event. A 2.3m x 50cm area in the centre of the platform is designated as the “Common Zone”. This zone, delivery pockets and start square will have tape bounding them as shown in the figure. The floor of the platform shall be made of wood and finished with matt black paint and the lines taped out with 1cm wide yellow reflective tape. The specifications of this tape are as follows:

Material Name : Fasign reflective sheeting.

Company: Fasign Reflective films.

Colour : Yellow.

Local Rep details: Teck Seng Enterprises Pte LTD

14, Eunos Tech Park, Tel: 6742-3035, Fax: 6842-0233

- 2.3 A total of 30 of each coloured pellets will be placed (total 60). The orientation and layout of the coloured pellets placed on any part of the colony platform will be decided by the judges but each setup will be kept consistent for all teams.

3. COLOURED PELLET SPECIFICATION

- 3.1 The coloured pellets will have a diameter of 25.4mm (1 inch) and have a general height of 20mm +/- 2mm height variation. (See figure 2)

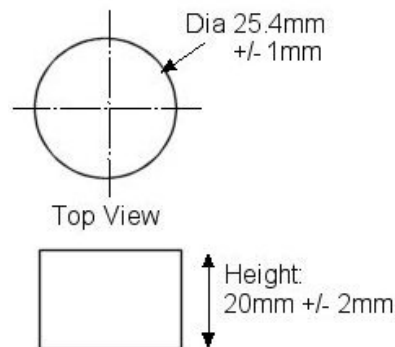

Figure 2 Specification of coloured pellet

- 3.2 The material specification of the pellets is as follows:

Green (Nyloil)	RS 771-162
Blue (Tuffset)	RS 771-538 (RS Catalog April 2006/2007 - Pg 1693)

4. ROBOT SPECIFICATION

- 4.1 The length and width of the robot shall be restricted to a square region of 15 cm x 15 cm. During collection and delivery, feelers or extending probes, collecting arms etc. of the robot should not extend beyond the 15cm x 15 cm area. There is no restriction on the height of the robot. The weight of each robot is restricted to 5 kg.
- 4.2 The robots must be fully autonomous with their own locomotion and must receive no outside help. The robots are however free to communicate wirelessly with each other for cooperative benefits.
- 4.3 One robot must be designated as a “Master” and the other a “Slave”. The “Master” will command/instruct the “Slave” to move out of the Start Area at the beginning of the competition. See “Section 5 - Rules for the Contest” for further details.
- 4.4 Each robot must have color identification patch/patches of a minimum size of 25cm² each that is visible to the judges at all times and robot orientation. The color of the patch corresponds to the color of the pellets the robot is disposing.
- 4.5 The methods, collection and delivery are at the discretion of the builder. The method of propulsion is at the discretion of the builder, provided the power source is non-polluting.
- 4.6 If any part of a robot should drop off while it is negotiating the platform, it will not be allowed to continue its run on the platform and will be removed.

5. RULES FOR THE CONTEST

- 5.1 The goal of the robot pair is to detect various coloured pellets placed in any area of the platform and to deliver them to their respective pockets. The collection and delivery strategy is left to the robot builder. The robot builder is free to decide on the technique for identifying the colour, detecting the location of the coloured pellets on the platform, and then deciding on a collection and delivery strategy to take it to the respective area. A cooperative strategy

between the two robots can be used to increase the productivity of the collection and delivery of the colour pellets.

- 5.2 The robots are restricted in its range of exploration. The robot starting in Start Area 1 is free to move within Zone 1 and the Common Zone only, and the robot starting in Start Area 2 is free to move within Zone 2 and the Common Zone. The robot starting in Start Area 1 is not allowed to go into Zone 2 and the robot starting in Start Area 2 is not allowed to go into Zone 1. Stray robots and robots which interfere with pellets not in their allowed zones will have to be restarted in their corresponding Start Area and the pellets it is carrying/ moving/ pushing removed from the platform. Robots are only allowed to deposit pellets into the delivery pocket in its own Zone, i.e. a robot starting in Start Area 1 can only deposit pellets into the delivery pocket in Zone 1 and not allowed to deposit pellets in the delivery pocket in Zone 2.
- 5.3 A robot (free moving, searching, collecting, pushing pellets) in the common zone when reaching its separator line (separating its allowed and disallowed zones) must take evasive actions to prevent it from going into the disallowed zone. Evasive actions include stopping & turning back/away, stopping & reversing or steering away. These actions must take the robot further into its allowed zone and not further into the disallowed zone. These actions will look no different to those when it is reaching the perimeter line which prevents the robot from falling off the arena.

A robot moving/steering along its separator line can have a small portion of it crossing into its disallowed zone. This portion will be "identical" to that amount when it is moving/steering along the perimeter lines. So the way the robot handles the separator and perimeter lines are identical. A robot moving/steering along the separator line may touch/brush pellets in the disallowed zone but it is not allowed to push the pellet along in front of it and not allowed to collect the pellet. A robot taking evasive actions (as described above) when reaching the separator line may touch/brush pellets in the disallowed zone but it is not allowed to collect it.

This provision is for handling between zone peripheral issues and must not be systematically exploited to gain unfair advantages.

- 5.4 Each correctly delivered pair of colour pellets in its colour delivery area will be awarded 2 points, and each incorrect colour pellet in any pocket will have 1 point deducted from the total score. For every pellet which does not form a successful pair will have 1 point deducted from the total score. One green and one blue pellet are deemed a pair of pellets.

Example: Blue Delivery Area: 10 Blue / 3 Green collected and deposited

Green Delivery Area: 15 Green / 1 Blue collected and deposited

Scoring: 10 successful pairs = 20 points

3 + 1 wrong pellets = -4 points

5 unsuccessful pair pellets = -5 points

Total Score = 11 points.

- 5.5 The competition time for each robot pair starts from the moment the judges give the signal to move off from the starting area.
- 5.6 At the end of the competition time, only pellets in the pockets will be counted. Pellets that are still held by or left in/on the robots will not be counted.
- 5.7 The starting procedure of the robot should be simple and must not offer a choice of strategies to the handler. The robots shall be placed within the Start Areas. The "Master" robot shall be started by pressing a "start" button once by one handler under the officials' instructions. The "Master" robot will then instruct/command the "Slave" robot to start.

Failure of the “Slave” robot to start immediately after the Master has started (moved off) at the beginning of the competition will incur a penalty of 10 points and constitute 1 restart. Manual starting of any robot after the initial Master start will constitute 1 restart. Throughout the duration of the robot's performance, the handler shall not enter any information into the robot.

- 5.8 Each team is allowed a maximum of 5 restarts. All restarts require the approval of the presiding Judges before the robot(s) can be removed from the arena. The team will be disqualified if the robots were handled within the arena without approval.
- 5.9 In general, restarts are only allowed when robots crash or are out of control.
- 5.10 Robots that are restarted in the start area will have any coloured pellet that it is carrying or moving/pushing by the robot be removed from the platform. The pellets will not be returned back to the platform. The final decision of which exact pellets are to be removed will rest with the judges.
- 5.11 Team members will not be allowed to handle the coloured pellets. Only officials are allowed to handle the coloured pellets in any situation (e.g. to clear the delivery area, re-site a coloured pellet etc...)
- 5.12 If a robot handler elects to retire because of technical problems, there will be no appeal for a second attempt.
- 5.13 If only one robot remains in the competition, there will be no more restarts for the team.
- 5.14 Only one pair of robot handlers per entry is allowed. The same robot handlers from a previous entry are not allowed to handle another entry's robots.
- 5.15 A robot which correctly delivers at least 5 pairs of pellets qualifies itself for a prize. Prizes will only be awarded to the top 3 teams from different institutions with the top 3 positive overall scores of more than 10.

6. CAGING

- 6.1 All robot entries will be caged 15 minutes before the start of the event.
- 6.2 Robot entries are not allowed to charge the batteries of the robot during caging but are allowed to cage spare batteries along with their robots.

7. CLONING

- 7.1 In accordance with the spirit of the competition, clones among the winning entries will only be awarded one prize. Clones will be identified during the "caging" procedure.
- 7.2 Clones are robots with substantially identical physical appearance and working principles.
- 7.3 When in doubt, the decision of the Judges will be final.

8. TIE-BREAK

Should a tie break be required because both teams have equal points, the tie break will be decided on the team which had the fastest successful 1st pellet delivery time.