

Singapore Robotic Games 2000

23 – 25 MAY 2000

RULE BOOK

V 4.3

20 MARCH 2000

SINGAPORE ROBOTIC GAMES 2000 MAIN COMMITTEE MEMBERS:

<u>Name</u>	<u>Dept, Organisation</u>	<u>Tel</u>	<u>Fax</u>	<u>E-mail</u>
Mr. Peter Chai Oon Heng	NYP/SEG/MSG	550-0763	452-0400	Peter_CHAI@nyp.gov.sg
Mr. Austin Goh	FSI/NYP	550-0549	452-0400	Austin_GOH@nyp.gov.sg
Mr. Keh Chow Toon	GSI/NYP	550-0946	454-9871	KEH_Chow_Toon@nyp.gov.sg
Mr. Leong Kum Cheong	NYP	550-0923	452-0400	LEONG_Kum_Cheong@ nyp.gov.sg
Mr. John Heng Kok Hui	MPE, NTU	790-5900	792-4062	mkhheng@ntu.edu.sg
Dr. Gerald Seet	MPE, NTU	790-5600	792-4062	mglseet@ntu.edu.sg
Dr. Andrzej Sluzek	SAS, NTU	790-4592	792-6559	assluzek@ntu.edu.sg
Mr. Yek Tiew Ming	ITE	260-6111	260-1993	yektm@ite.edu.sg
Mr. Alex Ho Tai Tong	ME, NP	460-6550	467-7384	htt@np.ac.sg
Mr. Hui Tin Fatt	TDC, NP	460-6190	463-4745	htf@np.ac.sg
Dr. Jagannathan K	ECE, SP	772-1369	772-1974	jagkan@sp.ac.sg
Mr. Lee Yum Fun, Gary	MME, SP	772-1461	772-1975	garylee@sp.ac.sg
Mr. Toh Ser Khoon	ECE, SP	772-1218	772-1974	SerKhoon@sp.ac.sg
Dr. Subramaniam	S'pore Sc Centre	560-3316	565-9533	subra@sci-ctr.edu.sg
Mr. L. Somasundaram	Engrg, TP	780-5602	787-4958	somasun@tp.ac.sg
Mr. Peter Lim Shee Soon	Engrg, TP	780-5517	787-4958	sheesoon@tp.ac.sg
Dr. Marcelo H. Ang Jr.	MPE, NUS	874-2555	779-1459	mpeangh@nus.edu.sg
Dr. Sam Ge Shuzhi	EE, NUS	874-6326	779-1103	elegesz@nus.edu.sg
Mr. Ruan Zhilong	EE, NUS	874-4847	779-1103	elerzl@nus.edu.sg
Mr. Yee Choon Seng	MPE, NUS	874-2137	779-1459	mpeyeecs@nus.edu.sg

SRG Home Page : <http://guppy.mpe.nus.edu.sg/srg>
Rules in the SRG Home Page will be used eventually in the Games.

TABLE OF CONTENTS

1. Legged Robot Race (Obstacle Track)	1
2. Legged Robot Marathon Race	4
3. Wall Climbing Robot Race	8
4. Open Category	12
5. Pole Balancing Robot	14
6. Gladiator	19
7. Micromouse Competition	23
8. Obstacle Avoidance Robot Competition	29
9. Trash-Bin Disposal Robot Competition	32
10. Cat and Mouse - The Scavengers	36
11. Robot Soccer Competition	40
12. Schools' Robotic Games - Smart Delivery Robot	48
13. Version Notes (V4.3)	49

LEGGED ROBOT RACE (OBSTACLE TRACK)

1. OBJECTIVE

To design a Legged Robot to travel on a designated track by either walking, running or hopping.

2. SPECIFICATIONS OF ROBOT

- 2.1 The robot must have at least one leg. There is no limit to maximum number of legs used. The maximum length and maximum width of the robot is restricted to a 1m x 1m square area in the starting zone. There is no height restriction on the robot. There is no restriction on the dimension and geometry of the robot once it started each race attempt (ie: once any part of the robot crosses the starting line.)
- 2.2 The robots must be completely autonomous. It should contain both the controller and power units. The robot must not weigh more than 10 kg.
- 2.3 Radio-frequency (RF) control is strictly prohibited in the robot design except for start/stop operation of the robot (i.e., remote push button to start and stop the operation of the robot.)
- 2.4 Each leg of the robot must consist of minimum two limb segments and demonstrate relative motion between the limbs to realise a walking motion.
- 2.5 The limbs of the robot must include some means of controlled motion to realise the walking, running, and/or hopping action for the robot. The following are some examples NOT considered as a legged robot:
 - Rotating wheel with spokes or any other structure sticking out radially to represent 'feet'.
 - Traction belt with studs or roller chain with 'feet' mounted in any orientation.
 - Robot, with feet or any floor contact point, mounted with motion-assisted roller wheel(s) is strictly prohibited
- 2.6 Locus for every feet of the robot cannot be higher than its associated pivoting joint.

3. SPECIFICATIONS OF RACE TRACK

- 3.1 The race-track is a raised platform of a fixed width of 1m and a maximum length of approximately 10m (not inclusive of starting zone and finishing zone.) It comprises of straight and circular sections connected together to make up the entire length. The circular section consists of a one-eighth circular path (45-degree sector) with radius of 1m (with respect to the longitudinal centerline of the path). The straight segment consists of 1 m straight paths. There will be a 1-meter **Starting Zone** and a 1-meter **Finishing Zone** at the start and the end of the race-track.
- 3.2 The track is constructed with 1/4-inch plywood with circular and/or straight sections raised about at either 50 mm or 100 mm off the ground. It will be lined with 3 mm thick black rubber mat. It is designed to support a robot with a maximum weight of 10 kg. Each section of the track is not expected to be perfectly level and it may be uneven. Track sections at the same elevation are joined with a maximum step at the

joints of 5 millimeters. There is a 50 millimeters wide retro-reflective tape (3M Scotchlite - Industrial Grade) in the middle of the track for navigation purpose.

Figure 1 shows a top view of an example of a competition race-track. It consists of 4 straight segments (A) and 8 circular segments (B). The segments are at different elevations of 50 mm or 100 mm off the ground.

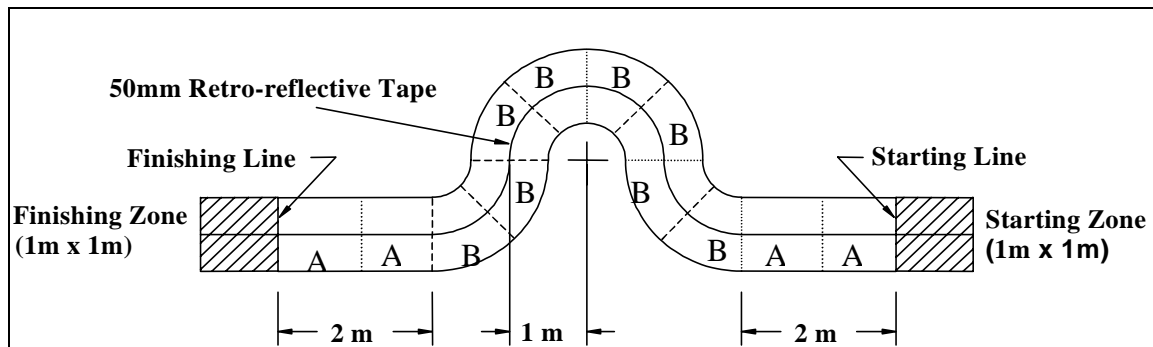

Fig. 1 Sample Legged Robot Race Track

4. RULES OF COMPETITION

- 4.1 The robot will be “caged” at 15 minutes before the start of the competition. (This includes approved electronic spare parts and spare power unit. Mechanical spare parts are not required for the “caging” exercise.) Once the competition starts, no individual is allowed to access the robots in the “caging” area.
- 4.2 The robot is to start from a stationary position before the starting line in the Starting Zone. It has to travel along the designated track either by walking, running or hopping, or any other motion not identified as wheeled motion. A valid **Record Time** is measured from the instance any part of the robot crosses the starting line to the moment when the last part of the robot (trailing edge) crosses the finishing line. No parts of the robot are to be left behind in the race-track.
- 4.3 The robot must keep within the designated track during the race. The result is void if any part of the robot completely touches the ground or the robot fell off the track before fully crosses the Finishing line.
- 4.4 Each robot is given **4** minutes **Competition Time** to produce its best result (this include setup time) Team may withdraw temporarily within the 1st minute of competition and all successful run during the 1st minute (before they withdraw) will be voided. In this case, they will then re-start their entry at a later time, but will be given only **3** minutes competition time to produce its best result.
- 4.5 Winning is based on the shortest time to complete the FULL competition track. If the robot failed to achieve any single complete run within the Competition Time, the longest distance travelled at any single attempt will be recorded instead. As for the single attempt which started just before the lapse of the competition time, it will be allowed to continue till it crosses the Finishing line or step out / fall out of the track, and the result will be recorded.
- 4.6 The robot need not stop in the Finishing Zone. As there might not be any track provided after the Finishing Zone, it is the participants' responsibility to take care of their robot if it chooses to overshoot the Finishing Zone.

- 4.7 Modification of robot during competition is **STRICTLY PROHIBITED**. No extra parts are to be added to or removed from the robot once the competition time starts. On the other hand, the robot is allowed to change identical mechanical spare parts, electronic components (except for the control and memory unit) and power unit.
- 4.8 During the competition, chassis of each robot are not allowed to be modified and used by different controllers; likewise, individual controller is not allow to be fitted on different chassis to represent different entries.
- 4.9 All robots should be returned to the caging area or a designated location after its run. The teams are not allowed to take back their robots before the whole competition is concluded.

5. CLONING

- 5.1 In accordance with the spirit of the competition, clones among the winning entries will only be awarded one prize. Clones will be identified during the "caging" procedure.
- 5.2 Clones are robots with substantially identical physical appearance and walking mechanism. Scaling of the same mechanism is considered as cloning. Robots with the same mechanism but different driving principles will not be considered as clones.
- 5.3 When in doubt, the decision of the Judges will be final.

LEGGED ROBOT MARATHON RACE

1. OBJECTIVE

To design a Legged Robot to travel on a designated track by either walking, running or hopping on a flat terrain for a total distance of approximately 23.56 metres.

2. SPECIFICATIONS OF ROBOT

- 2.1 The robot must have at least one leg. There is no limit to maximum number of legs used. The maximum length and maximum width of the robot is restricted to a 0.6m x 0.6m square area in the starting zone. There is no height restriction on the robot. There is no restriction on the dimension and geometry of the robot once it started each race attempt (ie: once any part of the robot crosses the starting line.)
- 2.2 The robots must be completely autonomous. It should contain both the controller and power units. The robot must not weigh more than 10 kg.
- 2.3 Radio-frequency (RF) control is strictly prohibited in the robot design except for start/stop operation of the robot (i.e., remote push button to start and stop the operation of the robot.)
- 2.4 Each leg of the robot must consist of minimum two limb segments and demonstrate relative motion between the limbs to realise a walking motion.
- 2.5 The limbs of the robot must include some means of controlled motion to realise the walking, running, and/or hopping action for the robot. The following are some examples NOT considered as a legged robot:
 - Rotating wheel with spokes or any other structure sticking out radially to represent 'feet'.
 - Traction belt with studs or roller chain with 'feet' mounted in any orientation.
 - Robot, with feet or any floor contact point, mounted with motion-assisted roller wheel(s) is strictly prohibited
- 2.6 Locus for every feet of the robot cannot be higher than its associated pivoting joint.

3. SPECIFICATIONS OF RACE TRACK

- 3.1 The race-track is a raised platform of a fixed width of approximately 1.2m wide divide into 2 equal width (approximately 0.6m) path and is approximately 23.56m in length. There will be a central divider of 10mm thick and 50mm tall running along the entire track. The central divider is not a rigid wall for robot to make contact with but mainly as a guide for official to check whether any robot crosses the designated path.
- 3.2 The track comprises of straight and circular sections connected together. The circular sections consist of a circle quadrant of radius (with reference to the retro-reflective tape) 0.5m or 0.8 m (depending on inner or outer path on the track) with respect to the longitudinal centreline of the path. There is designated Start Zone and Finish Zone on the track.

3.3 The entire track is constructed with 1/4-inch plywood with circular and/or straight sections raised about 50 mm off the ground (if 50 mm track is not available, the entire track will use 100 mm height). It will be lined with 3 mm thick black rubber mat. It is designed to support a robot with a maximum weight of 10 kg. The joint between 2 track sections is **NOT** expected to be perfectly level and it may be uneven. Track sections at the same elevation are joined with a maximum step at the joints of 5 millimetres. There is a 50 millimetres wide retro-reflective tape (3M Scotchlite - Industrial Grade) in the middle of each path for navigation purpose.

Figure 1 shows a top view of the actual competition race-track which consists of a 11 straight segments and 10 circular segments forming a total close loop distance of 23.56 metres

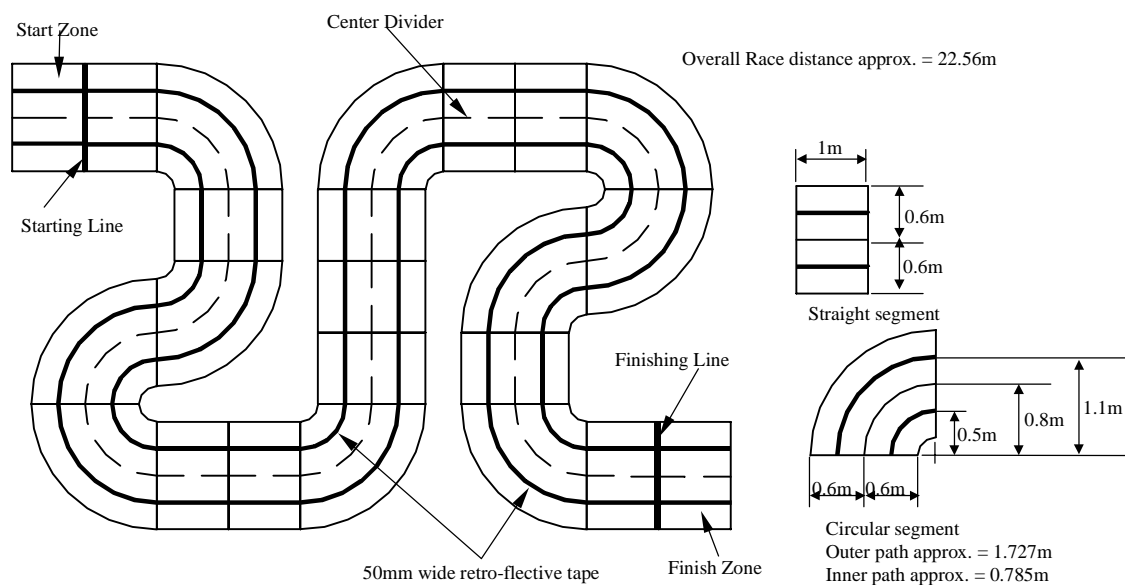

Fig. 1 The Legged Robot Race Track

4. FORMAT OF COMPETITION

4.1 There will be 2 phases in the competition:

- a) The Preliminary Matches
- b) The Knock-out Championship Matches

4.2 The Preliminary Matches

All robot entries will be randomly paired by drawing of lots. The odd number robot will run by its own. Every match will consist of 3 races. 2 robots competing in the race will be timed.

All the timing will be tabulated to determine the top 8 ranking for the next round of matches. If there are clones among the top 8 ranking, only the best clone will advance to the next round and the lower rank will be moved up.

The top 8 ranking will proceed to the Knock-out Championship Matches using Table of 8. (Note: If the total number of entries exceeded 30, table of 16 will be used to include more robots)

4.3 The Knock-out Championship Matches

The Table of 8 shown in Fig. 2 will be used. The pairing or opponents will go according to the ranking during the Preliminary Matches. Figure 2 shows the competition matches in a Table of 8.

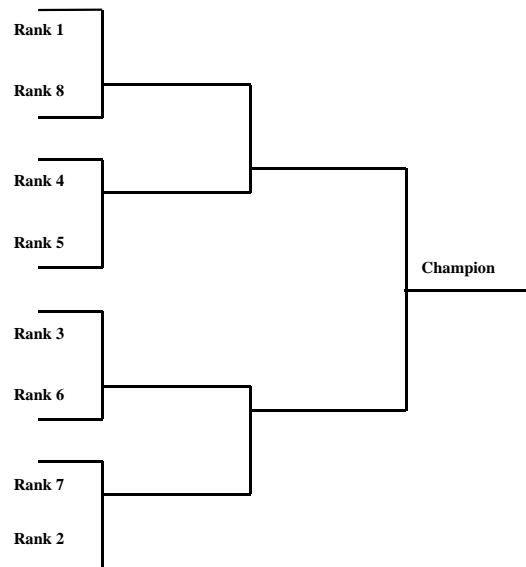

Fig. 2. Table of 8

Each Match consists of 3 races. The winner of each match is decided by number of winning races. 4 Winners of quarterfinal round will proceed to semi-final round after which 2 winners of semi-final round will proceed to the Championship round. The Champion is again decided by number of winning races.

5 RULES OF COMPETITION

- 5.1 Robot will be “caged” at 15 minutes before the start of the competition. The caged robot should be the full robot **PLUS** all necessary power units of the same rate capacity. Once the competition starts, no individual is allowed to access the robots in the “caging” area.
- 5.2 Robot is to start from a stationary position before the Starting Line at the Start Zone. It has to travel along the designated track either by walking, running or hopping, or any other motion not identified as wheeled motion. **Two** robots will be racing at any one time and the sequence will be determined by drawing of lots. The robot has to complete the entire competition race-track for each race.
- 5.3 Robot must keep within the designated track during the race. The result is void if
 - a) any part of the robot completely touches the ground or the robot falls off the track before fully crosses the Finishing line. Or
 - b) any part of the robot crosses the central divider.

If any of the above situations occurs, the participant, under instruction from the judge, must remove their robot immediately without disturbing the other robot in the same race.

- 5.4 The race and race time both starts by the blow of a whistle. In the **Preliminary Matches**, a valid **Recorded Time** is measured from the time then the whistle is blown until the moment when the last part of the robot (trailing edge) crosses the demarcation line at the Finish Zone. Any robot moved before the whistle is blown will be considered a **False Start**. Only 1 warning will be given to False Start any robot and any subsequent False Start will be considered has lost the race.
- 5.5 No parts of the robot are to be left behind on the race-track. Winning is based on the best time of a completed race for each robot. If the robot failed to achieve any single complete run for any of the races, the longest distance travelled at any single attempt will be recorded instead
- 5.6 During the competition, If the robot, under any circumstance, does not demonstrates any positive action to start or complete the race (eg: always crash or run out of track for no apparent reason) may be asked to retire by the discretion of the judges while the other robot still carry on the competition on its own.
- 5.7 Once the robot has started its race, the robot handler can only access the robot after it crosses the Finishing Line at the Finish Zone on the competition track or the robot run out of the track completely. The robot need not slow down or stop after completing on the competition track.
- 5.8 Modification of robot during competition is **STRICTLY PROHIBITED**. No extra parts are to be added to or removed from the robot once the competition time starts. Every robot must have their individual parts and no sharing is allowed. The only replacement in the robot is the power unit which was declared during caging. **Replacement of power unit is not allow in a same Match**. Robots are not to share each other's power unit.
- 5.9 All robots should be returned to the caging area or a designated location after its run. The teams are not allowed to take back their robots before the whole competition is concluded.

6. CLONING

- 6.1 will only be awarded one prize. Clones will be identified during the "caging" procedure.
- 6.2 Clones are robots with substantially identical physical appearance and walking mechanism. Scaling of the same mechanism is considered as cloning. Robots with the same mechanism but different driving principles will not be considered as clones.
- 6.3 When in doubt, the decision of the Judges will be final.

WALL CLIMBING ROBOT RACE

1. OBJECTIVE

The aim of this event is for mobile robots to demonstrate their horizontal and vertical surface climbing abilities during a race.

2. THE COMPETITION ENVIRONMENT

- 2.1 The wall is shown in Figure 1 below. It consists of three sections: a 2 metre long horizontal section (section A) on the ground followed by a 2 metre high vertical section (section B) followed by a 2 metre long horizontal section (section C) at the top, with each section 1.2 metres wide.

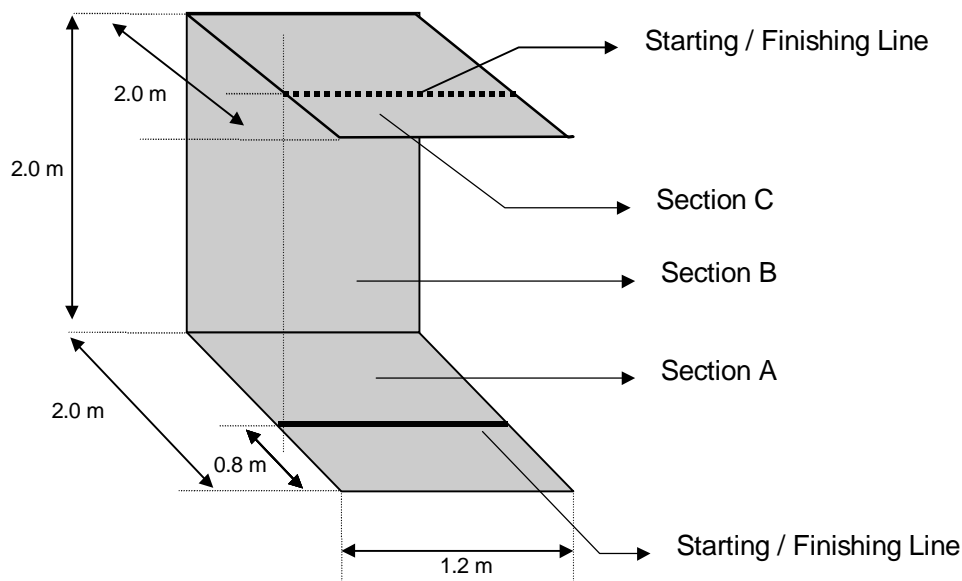

Figure 1: The wall for the wall-climbing robot race

- 2.2 The surface of the wall will be covered with mild steel sections with a thickness of at least 0.003 metres. The wall will have a matt black surface finish.
- 2.3 Starting / finishing lines will be located 0.8 metres from the beginning of the horizontal section on the ground (section A) and 0.8 metres from the end of the top horizontal section (section C). The line in section A will be used to demarcate the maximum size of the robot.
- 2.4 The supporting structure for the wall will have provision for *two* safety cables to be attached to the robot so that both cables can be used simultaneously during the race (*not* shown in Figure 1.)
- 2.5 The wall sections A and B will each have one obstacle consisting of a horizontal bar made of non-magnetic material (not shown) with 0.03 m X 0.03 m square cross-section will be placed laterally across the entire width the section. Both of these obstacles will be placed such that one of its sides is touching the wall section. Both of these obstacles will have reflective tape fully covering the exposed sides of the obstacle. The obstacle across wall section A will be placed randomly such that it is at least 0.5 m away from the edge where it meets the next wall section (wall section B)

and also at least 1.0 m from the opposite edge. The obstacle across section B will be placed randomly such that it is at least 1.0 m from the edge that meets the lower wall section (wall section A) and at least 0.5 m from the edge that meets the upper wall section (wall section C).

2.6 The wall structure will be constructed such that it conforms to the following:

(a) the length of each wall section should be $2000 \text{ mm} \pm 5 \text{ mm}$.

(b) the angle formed between two adjacent wall sections should be $90^\circ \pm 0.5^\circ$.

The wall will be deemed to have satisfied criteria (a) and (b) above and be considered fit for use if each of the two distances between diagonally opposite corners (using the side view in Figure 1) lies in the range 2733 mm to 2847 mm.

3. THE COMPETITION

3.1 Robots will start from a stationary position anywhere before the starting line on the horizontal section (section A) on the ground.

3.2 On reaching the vertical section (section B) the robots will attempt to climb up the vertical section and subsequently climb 'upside-down' to the end of the top horizontal section (section C.) On reaching the end of the top horizontal section, the robot will attempt to return to the starting point by climbing back through sections C, B and A in sequence. The sequence of wall sections to be climbed from start to finish is A-B-C-C-B-A.

3.3 The robot that completes the highest number of wall sections in the sequence according to paragraph 3.2 above wins.

3.4 In the event that two or more robots complete the same number of wall sections, the scoring system based on the formula described below will be used. This scoring system awards points so that the robot that completes either the entire course or the highest number of wall sections in the sequence described in paragraph 3.2 above (in the event that there are no robots that can complete the entire course) in the shortest time wins. The robot that scores the highest number of points according the following formula wins:

$$\text{Score} = 200 \times W - T + R + S$$

where W = The number of wall sections completed by the robot *excluding the first time it completes the wall section A*, in the sequence according to paragraph 3.2 above.

T = The time taken (in seconds) by the robot to complete W wall sections.

R = A bonus of +50 to be awarded if the robot demonstrates a minimum degree of consistency in performance by successfully completing the entire course of all wall sections in the sequence according to paragraph 3.2 above in each run on at least two consecutive runs made during the race without falling off the wall.

S = A bonus depending on the extent that the robot is self contained (autonomous). To be eligible for the bonus, S , the robot must successfully complete the entire course of all wall sections in the sequence according to paragraph 3.2 above at least once during the

race without falling off the wall. The bonus, S, will be awarded according to the table below:

<i>Type of Robot</i>	<i>Bonus</i>
1. Totally self-contained robot with internal power source and internal automatic-control / intelligence.	+400
2. Partially self-contained robot with either external power source or external automatic-control / intelligence.	+200
3. Robot with both external power source and external automatic-control / intelligence.	+100
4. Human controlled wall climbing mechanism ² with internal or external power source that requires manual control .	0

Notes:

1. The bonuses R & S both apply to the best score obtained by the robot during the race.

2. Any robot which is manually re-configured or adjusted at any time after caging has taken place will be considered to be a human controlled wall climbing mechanism and hence not entitled to the bonus S.

- 3.5 A robot is deemed to have started once any part of the robot crosses the starting line in the wall section A.
- 3.6 A robot is deemed to have completed its climb through a particular wall section when it fulfils all of the following conditions (a), (b) and (c) *in sequence*:
- (a) the robot touches the wall section that it is about to complete
 - (b) the robot simultaneously touches both the wall section that it is about to complete as well as the next wall section in the sequence of wall sections that is consistent with its direction of travel
 - (c) the robot ceases to touch the particular wall section that it is about to complete and touches the next wall section in the sequence that is consistent with its intended direction of travel.

The above conditions apply to all wall sections except in the following cases:

- (i) when the robot completes its climb through the wall section C *for the first time* in the sequence according to paragraph 3.2 above
- (ii) when the robot completes the last wall section (wall section A) in the sequence according to paragraph 3.2 above;

In both cases (i) and (ii) above, the robot is deemed to have completed its climb through the wall section only when the entire robot has crossed the finishing line placed within that particular wall section.

- 3.7 For each team of participants, the race will begin once the participants remove their robot from the caging area. Once the race begins, each team of participants will be given a maximum of 10 minutes to produce its best result. No extra time will be given at the beginning for participants to set-up or prepare their robots.
- 3.8 After the race begins, any physical handling of the robot such as touching, pulling of cables or pushing of the robot during a climb will disqualify the result of that climb. However if a robot falls off while climbing the wall, using the safety cables to break the fall of the robot is allowed and the result of the climb will be determined as specified in paragraph 3.3 & 3.4 above.

- 3.9 During the first two minutes of the 10-minute race, participating teams may seek permission from the judges to temporarily withdraw because of technical difficulties and re-enter the race at a later time. If a participating team is allowed to re-enter the race then it will have a reduced time of 5 minutes both to prepare their robot for action and to produce its best result at the same time. All race results obtained by the robot previously before the temporary withdrawal will *not* be considered. Permission to temporarily withdraw from the race and re-enter at a later time will not be automatically granted and the judges will use their discretion in granting permission on a case-by-case basis. Each participating team may only temporarily withdraw and re-enter the race once.

4. THE ROBOTS

- 4.1 The dimensions of each of the competing robots must *not* exceed 0.75 metres in length, width and height *at all times* while the robot is in operation. For non-autonomous designs these dimensions apply for the mobile or climbing part of the robot only.
- 4.2 The weight of each of the competing robots must *not* exceed 10 kilograms. For non-autonomous designs this weight restriction applies to the mobile or climbing part of the robot only.
- 4.3 Competing robots must not have parts removed or added to them during the competition except for replacement of batteries or for repairs essential to the operation of the robot. The competing robots are not allowed to discard any part of their chassis during operation. The competing robots must not use chemical or combustion power methods.
- 4.4 The competing robots must not damage the competition environment including the wall and its supporting structure and the sensors in any way.
- 4.5 The competing robots must not endanger the judges and the spectators in any way. All competing robots must be firmly secured with two safety cables at all times during operation.
- 4.6 A robot will be disqualified during the competition if it endangers the judges, the participants or the spectators in any way during the competition, or if it damages the competition environment. Alternatively a robot may be banned from competing if, in the opinion of the judges, it is likely to pose a safety hazard or cause damage to the competition environment.

5. CLONING

- 5.1 In accordance with the spirit of the competition, clones among the winning entries will only be awarded one prize. Clones will be identified during the "caging" procedure.
- 5.2 Clones will be identified by the working principles of the whole robotic system, such as the sequence of operations during the crossing of obstacles and negotiating the wall bends.
- 5.3 When in doubt, the decision of the Judges will be final.

OPEN CATEGORY

1. OBJECTIVE

The contestants are to demonstrate a robot that performs interesting tasks for applications such as in entertainment, domestic chores, industry etc.

2. BRIEF DESCRIPTION

2.1 The competing robots, which can be self-navigating or remote-controlled, will perform their capability on a 5m x 5m contest arena for a period of time.

2.2 The robots may move freely around the arena or be in a static position.

3. RULES AND GUIDELINES

3.1 The competing robots can start from any point in the contest arena.

3.2 A total duration of up to 10mins is allocated for setting up the robot and any accessory equipment and demonstration of its capability. The time duration will be measured from the moment the contestants enter the arena. If more than 10 minutes elapsed, the robot must be removed from the arena.

3.3 In the case where the contestants wish to employ radio control, they should inform the secretariat in advance. Contestants should not broadcast radio signals while another contestant's robot is performing.

3.4 In the case that a robot requires special accessory equipment or tools during its performance, the contestants will provide such items.

3.5 In the case that a robot performance is to be accompanied by music, the contestants should provide the means to reproduce this music.

3.6 There is no specific flooring material of the contest arena. The flooring will very much depend on the available contest site. However, if there is a special requirement such as carpet, the contestants will have to provide for it.

3.7 One power point of 220/230V, 50 Hz supply will be made available. However, the teams are to provide their own power adapter and extension means if it is required.

3.8 For air supply, the contestants are to provide their own air compressor units if necessary.

3.9 The designs of the competing robots must be original and unique. No two identical designs are allowed in the competition.

3.10 The expenses incurred in transportation and setup of equipment is to be borne by the individual teams.

3.11 The boundary for the area will be black or white depending on the floor color.

3.12 Winning robots will not be allowed to participate in the subsequent two Robotics Games.

3.13 Robots that can, in principle, compete in other SRG events (e.g. Pole Balancing Robot competition) should not be allowed to compete in the open category event.

4. JUDGES

- 4.1 A panel of 3 or 5 judges will be present to judge the event.
- 4.2 All judges will be external judges except for the chief judge.

5. JUDGING CRITERIA

Degree of Innovation	20%
Entertainment Value and Aesthetics	30%
Complexity & Intelligence	20%
Performance to expectation	30%

POLE BALANCING ROBOT

1. DEFINITION:

Any mechanism which supports an inverted pendulum which is free to swing around a horizontal axis with one degree of freedom and balances it to keep it vertical by moving the point of support shall be considered "the pole balancing robot."

2. ACCEPTABLE VERSIONS:

- 2.1 The inverted pendulum may be supported by a vehicle moving along a straight line. Any other innovative design which does not violate the spirit of the competition may be allowed at the discretion of the judges subject to the following conditions:
- 2.2 The inverted pendulum must be free to swing. It must be balanced by moving the pivoted support point parallel to the plane of the swing. The pivot must be fixed to the vehicle.
- 2.3 The robot must use a standard contest balance pole specified by the organisers. A sample pole will be supplied for the institutions participating in the competition. The pole material will be aluminium.
- 2.4 There is no size restriction on the robot. The overall size will be such that it would be able to operate on the table provided by the organisers. No part of the robot, other than its wheels, must touch the surface of balance table. It must not fall off the competition table surface during the operation.
- 2.5 Balancing the pendulum/pole using any form of gyroscopic principle is not admissible.
- 2.6 A self-balancing design in which the pendulum will always stand up due to the use of a balance weight below the axis of rotation is also not admissible.
- 2.7 There should be no relative motion between the pole-support axis and the body of the vehicle.
- 2.8 No guide rails are allowed.
- 2.9 The vehicle must be *completely* autonomous, with no wires connected externally and with no RF signals or power lines coming from outside.

3. POLE-SUPPORT MECHANISM AND OVERALL SIZE:

- 3.1. The supporting mechanism must be compatible to the diagram shown in Fig. 1. Ball bearings must be used in the axle of rotation supporting the pole, only exception being the instrumentation potentiometer or encoder. If the potentiometer or encoder is driven through gears then the gear friction must be very small as quantified in section 3.2. It must be able to swing freely from -45° to $+45^\circ$ from the vertical position when the vehicle is positioned in region B.
- 3.2 The friction of the suspension mechanism is quantified as follows: The pole used for balancing is also used for this purpose. The robot will be placed upside-down to make the pole a regular pendulum.

For the test, the robot is supported upside down such that the pole support axle is along the vertical line A, marked on the wall or the platform built for this purpose. There will be two vertical lines on the right side. One (extreme right line B) corresponds to 45°

inclination of the pole. The second inner line C corresponds to 18° inclination of the pole, at a distance of 30 cm from line A.

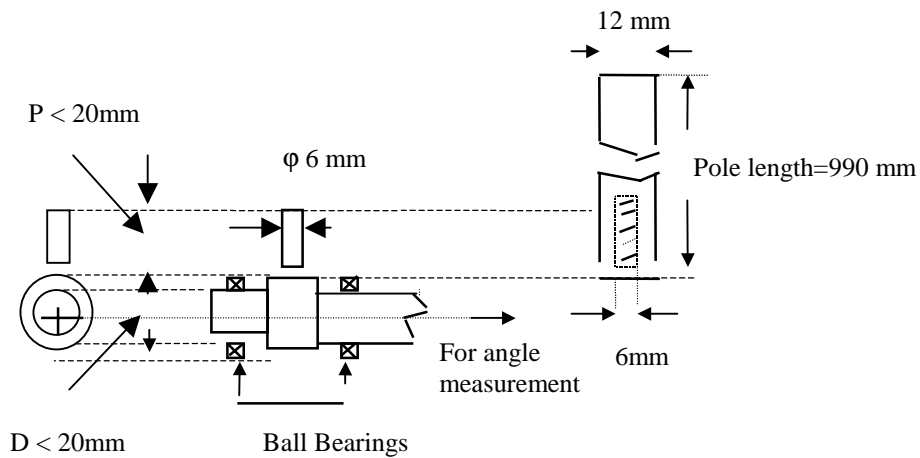

Fig.1. Pole Support Mechanism

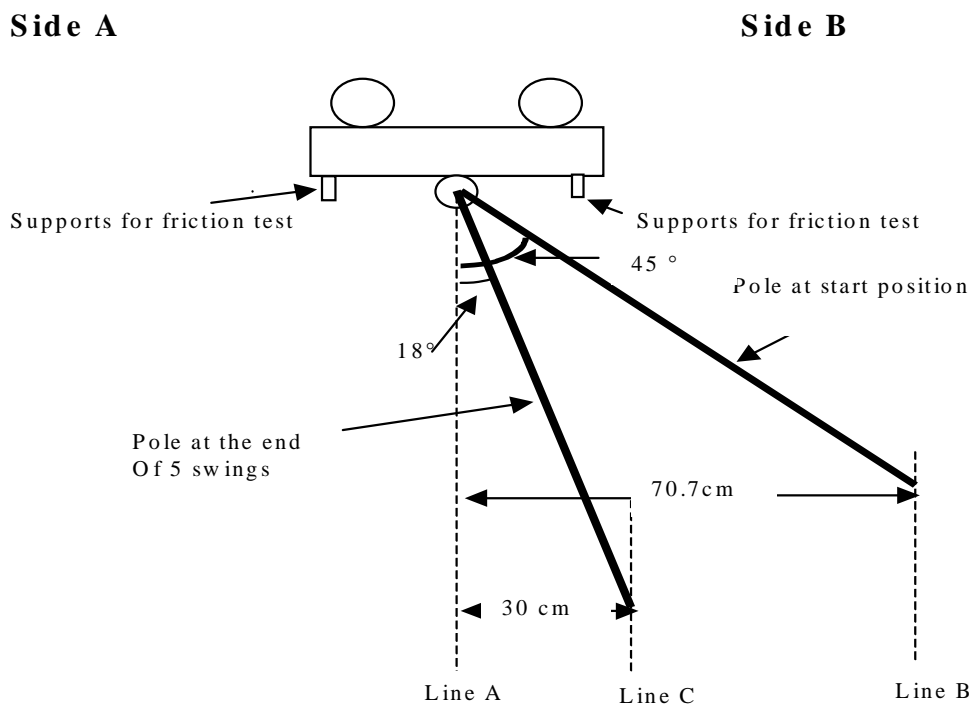

Fig.2 Friction Test Procedure with inverted Robot

The pole will be moved to side A to reach an inclination of 45° such that the tip touches the outer vertical line B and is released, so that it swings back and forth. At the end of the fifth swing cycle the pole should swing back to side A and reach a minimum angle of 18° such that the tip touches the inner vertical line C.

3.3. The organisers strongly recommend that the robots have projected supports perpendicular to the base plate at the front and back of the robot, to facilitate easy placement during friction test. See Fig. 3a. The dimensions of the support provided on the robot must be such that the inverted robot can be placed on the friction test structure shown in Fig.3.

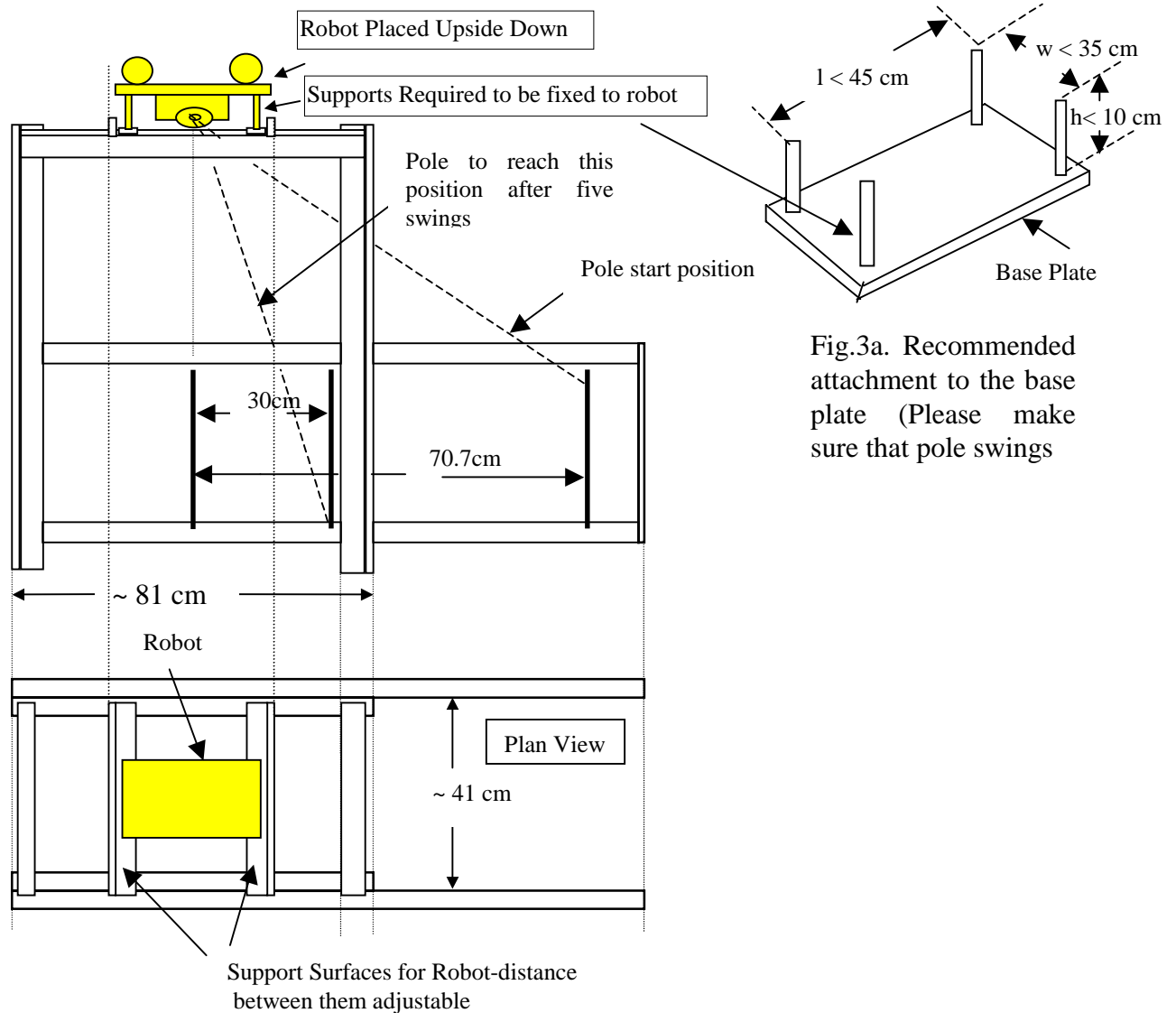

Fig.3a. Recommended attachment to the base plate (Please make sure that pole swings

Fig.3. Friction Test Structure

4. TABLE:

4.1 The competition table is shown in Fig.4. One common competition table will be used by all competitors. The gradient will be approximately 5.7 degrees. The edges between the inclined surfaces and the horizontal surface will be rounded off and there will be no joints at those edges. A neoprene rubber mat of 3mm thickness will be used on the top of the table to improve the grip of the wheels.

5. CAGING:

5.1 The robots will be caged before the competition before the friction test.

5.2 No switching of EPROMs or downloading of programs will be allowed, after caging.

5.3 Once the robot has been caged, no change of batteries will be allowed.

6. COMPETITION:

6.1 The robotic vehicle would operate on the top of the table provided. Please see Fig. 4. The table-top will have a slight gradient at the start (region A) and the end (region B) zones as shown in Fig. 4.

6.2 The vehicle will be placed within the region A (see Fig. 4). The operator may move the pole (the inverted pendulum) to an upright position and release it upon receiving the signal from the judges. The vehicle must balance the pole in the upright position for a minimum of 20 seconds without the vertical pole crossing the line X-X'.

6.3 Upon completion of the task (in 6.2 above), the vehicle should move across the line X-X' once, and move through the region B, until the pole clears the line Y-Y', without losing balance during transit, i.e. not hitting any part of the table or its own chassis.

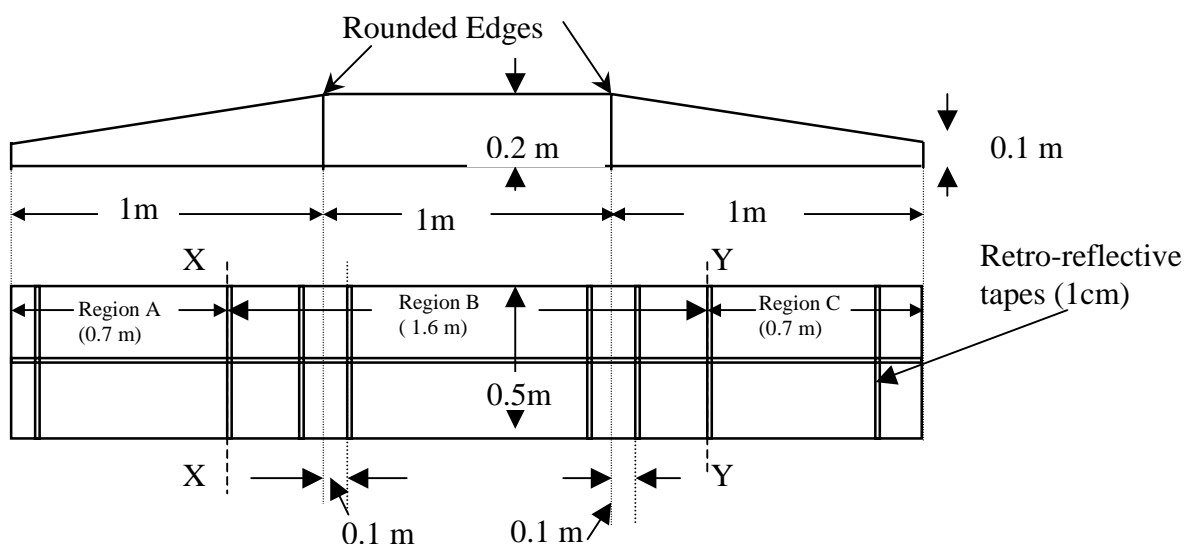

Fig.4. Pole Balancing Robot Table

6.4 Upon completion of task (in 6.3 above), the vehicle must retrace the path, cross the line X-X' again and get back to region A. This will complete one cycle. This time, during the retrace, the vehicle need not stay any length of time at region B or A, before the start of the second cycle.

6.5 The vehicle should repeat these cycles.

6.6 To count these cycles as successful cycles they must be followed by at least 20 seconds of static balancing at region A.

6.7 The robot may continue on (untouched) for more cycles, and *complete* them with 20 seconds of static balancing at the end, which if successful will be counted cumulatively.

6.8 If a robot is touched by the handler during the trial, it must be restarted for the next attempt.

7. NUMBER OF ATTEMPTS:

7.1 From the instant the team is called upon to take the arena, 2 minutes will be allowed for set up.

7.2 After the set up time, 5 minutes of *performance time* will be allowed for each robot. The *performance time* will start when the participant first releases the robot-pole. However if the set up time exceeds 2 minutes, then *performance time* will start automatically.

7.3 With in the time permitted, any number of attempts will be allowed. All the attempts must be *completed* within 5 minutes

7.4 The participants must vacate the competition area when the 5 minutes of *performance time* expires.

8. SCORING:

Final score = A x B x C

where A = 0 if the robot does less than 20 seconds of initial static balancing

A = 1 if the robot completes 20 seconds of initial static balancing

B = number of cycles achieved during run time

C = 1.5, if the robot successfully completes 20 seconds of "the final static balancing" within the performance time.

C = 1.0, if the robot starts "the final static balancing" within the performance time, but the 20 seconds of "the final static balancing" extends beyond the performance time.

C = 0.0, if the robot pole falls before the 20 seconds of "the final static balancing" is completed.

9. CLONING:

9.1 In accordance with the spirit of the competition, clones among the winning entries will only be awarded one prize. Clones will be identified during the "caging" procedure.

9.2 Clones are robots with substantially identical physical appearance and working principles.

9.3 When in doubt, the decision of the Judges will be final.

GLADIATOR

This game involves two robots combating in an arena. A robot is declared as the winner if it can force or push any part of the opponent's body to touch the ground outside the arena or when the judges declare its opponent as disabled/immobilised.

1. OBJECTIVE

To design an autonomous robot equipped with devices and mechanisms to force or push its opponent out of the arena.

2. LEVELS OF THE COMPETITION

2.1 This event comprises four progressive levels of competition as shown below:

- Preliminary Round : Round Robin [maximum of five teams to one sub-group]
- Quarter-Final : Knock-out system [Draw lots for line-up]
- Semi-final : Knock-out system
- Final : Knock-out system [followed by Sudden Death if there is a draw]

2.2 During the preliminary rounds [round robin], entries are divided into several sub-groups, each with a maximum of five entries. And entries in each sub-group will compete among themselves. Each game between two robots consists of three matches. The best of three matches wins the game and points will be awarded based on the following:

- Win : 1 point
- Draw : 0 point
- Lose : 0 point

The entry with the highest score from each sub-group will progress to the next level of competition.

2.3 Depending on the number qualified for the next level of competition, the judges reserve the rights to include a few entries from among the 2nd and 3rd placing, at appropriate level of competition to form the last eight entries for the quarterfinals and/or four entries for the semi-finals.

3 HOW THE GAME IS PLAYED

3.1 Every game comprises two robots fighting it out over three matches. Each match lasts 45 seconds. The task of each robot is to force or push its opponent out of the arena.

3.2 At the beginning of each match, the two competing robots are positioned behind the designated 'Start' point in their respective side of the arena. And a portion of the robot's body must be seen to be touching the centre line of the arena.

3.3 During the preliminary rounds (Section 3.2), robots assigned to each sub-group will compete against each other. In each game, the robot with the best of three matches wins and is awarded one point. After the rounds are completed, the robot scoring the highest points within each sub-group will progress to the next level of competition.

3.4 During the quarter and semi-finals, knock-out system is adopted. In each game, the robot with the best of three matches will progress to the next level of competition.

3.5 Tie Breaker

Whenever a tie occurs in the preliminary rounds [applies to selection of entries to next level of competition only], quarterfinals and semi-finals, it will be resolved through a tie-breaker system. This tie-breaker system uses a Dummy Robot [weighing between 5 kg to 10 kg] as a 'stand-in' opponent. This dummy robot will be positioned at the centre of the arena. Robots involved in the tie will compete individually against this dummy robot. A match time of 45 seconds is given to push the dummy robot out of the arena. The robot that can accomplish it in the shortest possible time wins. However, if both fail to push the dummy robot out of the arena when the 45-second match time is up, then both will not be eligible to proceed to the next level of competition.

3.6 One-minute Set-up Time

Robot handlers are given a 'one-minute set-up time' to prepare the robot before each match. If a robot is not ready after the one-minute is up, it would be deemed as a walk-over. The next match shall proceed immediately until all the three matches are played. A match can also commence early if both robots are ready before the one-minute set-up time is up.

When the match commences, each robot handler must activate his/her robot immediately. And the robot must move completely over the 'Start' line towards the opponent.

4. RULES AND REGULATIONS

4.1 A robot wins if it can force, wrestle or push the opponent until any part of the opponent's body makes contact with the ground outside the arena.

4.2 A robot is retired if :

- * it remains in the START corner after the match commences.
- * it fails to perform after the one-minute set-up time is up.
- * any parts/mechanisms falling completely out of the body during the competition.
- * any devices/mechanisms and weapons/tools extended out during combat and are not retracted at the end of each match to a position confined within the robot's dimensional limits. This is inclusive of all conditions such as being trapped by or entangled with any part of the opponent, etc. [No non-retractable projectiles/missiles are permitted, e.g., shooting]
- * any linear or rotary cutting devices or tools e.g. chopper, rotating saw blades are used.
- * any parts, tools or mechanisms falling out of the robot during combat
- * any suction, anchoring or similarly devices are used to hold the robot firmly onto the ground.
- * any dangerous devices such as high emf/frequency emitter, corrosive liquid, explosives, etc. are used as weapons.

4.3 Inspection of Robots

One hour before the competition commences; all participants must submit their entries for inspection by a panel of judges. After which the entries will be caged and displayed for public viewing.

4.4 After an entry has been submitted for inspection, no alterations, changes and/or modifications to their mechanical design, power supply, and /or electronic circuitry are permitted before and during the competition without the permission of the judges. Failure to observe this ruling will subject the participant with disqualification. However, before each level of competition i.e. quarterfinals, semi-finals and final, commences robots are allowed to replace their battery.

5. SPECIFICATIONS

5.1 Robots failing to meet any of the following specifications during the cage-in will be disqualified.

- * Weight of robot ≤ 10.0 kg
- * Physical dimensions : ≤ 300 mm [Length] x ≤ 300 mm [Width]
- * The height of the robot : >150 mm [Height]
- * Autonomous

5.2 Specifications of Dummy Robot

A plastic container with dimensions of ≤ 300 mm [diameter] x ≤ 300 mm [height] is used as a dummy robot. And a pack of rice weighing at least 5 kg will be placed inside the container. However, the overall weight of the dummy robot shall not exceed 10 kg.

6. ARENA

The 1 m x 2 m arena is made of 10 mm to 20 mm thick wood [of table-tennis table quality and finishes]. A centre line is laid length-wise with 25-mm reflective tape. The arena [table] is elevated at least 100 mm above the ground level. The boundary of the arena is marked with a white line [approximately 25-mm wide. The start lines and the arena centre are marked with [50 x 25] mm reflective tapes. All dimensions are subject to a ± 3 % general tolerance.

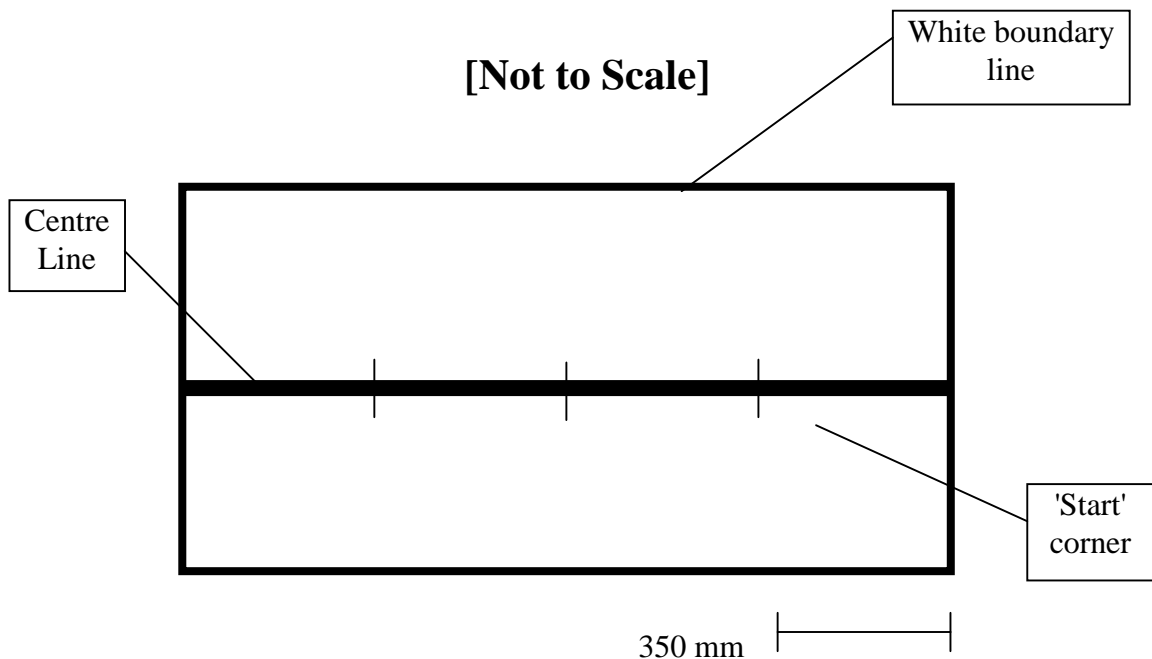

6. CLONING

- 6.1 In accordance with the spirit of the competition, clones will only be awarded one prize even though they may produce the best results.
- 6.2 Clones will be identified during the 'caging' procedure. Once identified, they will be grouped together separately and compete among themselves before the preliminary round commences. Eventually, only one of the clones is permitted to enter the preliminary rounds.
- 6.3 Clones will be identified by substantially identical physical appearance and working principles.
- 6.4 When in doubt, the decision of the judges will be final.

MICROMOUSE COMPETITION

INTRODUCTION

Micromouse is an autonomous mobile vehicle, which is able to navigate its way through an unknown maze from the start to the destination. It is also required to search for the best path between the start and the destination for the micromouse to run along this path in the shortest time.

The main challenge for micromouse designers is to build a fast moving wheel-driven robot. They need to work out the maze solving intelligence for the robot that is able to handle different maze configurations and compute the optimum path for the shortest fast-run time, and to control the robot to run at very fast speed without hitting the wall.

1. MAZE SPECIFICATIONS

- 1.1 The maze is be configured by placing walls along the grid-points formed by multiples of 18cm square. The squares are arranged in a 16 x 16 row-column matrix. The walls constituting the maze are in 5cm high and 1.2cm thick. Passageways between the walls are in 16.8cm wide. The boundary of maze is enclosed with walls.
- 1.2 White plastics make the maze walls. The maze platform is made by plywood and finished with black color matted paint. The maze walls shall reflect infra red light. The maze floor shall absorb it.

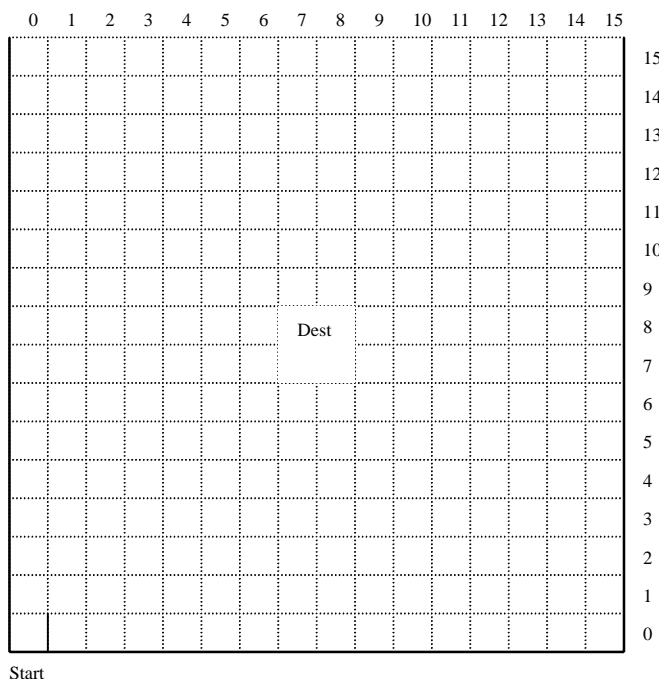

Figure 1: Start and Destination Points and Grid Lines for Maze

- 1.3 The starting position of the maze shall locate at one of the maze corner. There shall be three walls surrounding it. Its opening shall be towards destination that is the center of the maze, locating at the right of the starting square.
- 1.4 There are poles, in dimensions 1.2cm (length) x 1.2cm (width) x 5.0cm (height), locating at four Corners of each maze square. They are called lattice points. The maze shall be constituted such that there is at least one wall attached to each lattice point, except the lattice point that is locating at the center of the maze.
- 1.5 The accuracy of maze dimensions shall be within +/- 5% or 2cm; whichever is less. The assembly joints on the maze floor shall not involve steps of greater than +/- 0.5mm. The gaps between the walls of adjacent squares shall not greater than 1 mm.

2. MICROMOUSE SPECIFICATIONS

- 2.1 The length and width of any micromouse shall be within 25cm x 25cm. There is no limit on the height of the micromouse. The micromouse shall not change its dimensions while it is navigating along the maze.
- 2.2 The micromouse shall be fully autonomous and shall not receive any outside help throughout the contest.
- 2.3 The method of wall sensing is at the discretion of the designer, however; the micromouse shall not exert a force on any wall that is likely to cause damage. The method of propulsion is also at the discretion of the designer, provided that the energy source is non-polluted.
- 2.4 The micromouse shall not leave any parts on the passageway while navigating along the maze.
- 2.5 The micromouse shall not jump over, climb over, or damage the walls of the maze.

3. RULES FOR THE CONTEST

The crucial task of the micromouse is to navigate from the starting square to the destination square. This is called a run and the time taken is called the run time. Traveling from the destination back to the start is not considered as a run. The total time taken from the first time left the start square until the start of each run is also measured. This is called the search time. If the micromouse requires a manual assistance at any time during the contest, it is considered as a touch. A one-time penalty shall be added on those scores that are obtained after the touch. The run time, the search time and the touch penalty are to be used for the calculation of each score that the micromouse reaches the destination from the start successfully.

The micromouse competition is divided into three categories. They are the secondary schools (SSs) category, the junior colleges/institutes of technical education (JC/ITEs) category and the open (Open) category.

3.1 The Secondary Schools (SSs) Category

- 3.1.1 The SSs Category is opened for all full time students from secondary schools. Each school shall be limit to **Four** entries. However, the school may submit the excess entries to the Open Category provided they have more than four entries in this category. Each entry shall not be more than **Six** students and must have its own micromouse. No micromouse shall be shared by any entries neither in this category nor the Open category.
- 3.1.2 Each entry shall be given time limit of 8 minutes or 6 crashes to contest on the maze. The micromouse may make as many runs as possible within time limit provided the micromouse does not crash more than 5 times.
- 3.1.3 The score of a micromouse shall be obtained by computing a handicapped time for each run as follows:

Score of Current Run (reached the destination successfully) = Run Time +
Search Penalty + Touch Penalty

Search Penalty = $1/60^{\text{th}}$ of the Search Time, in seconds

Touch Penalty = 2 seconds

For example, if a micromouse, after being on the maze for 4 minutes without being touched, starts a run that takes 20 seconds to reach the destination; the run will have a handicapped time score of $20 + 1/60^{\text{th}}$ of $(4 \times 60 \text{ seconds}) = 24$ seconds. However, if the micromouse has been touched before the run, an additional touch penalty of 2 seconds is added on giving a new handicapped time score of 26 seconds. The run with the fastest handicapped time score for each micromouse shall be the official time score of that micromouse. The accuracy of time score is to the nearest $1/100^{\text{th}}$ seconds.

- 3.1.4 The run time shall be measured from the moment that the micromouse leaves the starting square until it enters the destination square. A run shall be complete only if the whole of the micromouse enters the destination square.
- 3.1.5 A computer timing system with electronic triggering devices shall be used for measuring scores of each micromouse. The electronic triggering devices are locating at the exit and entry of the starting square and the destination square respectively. The triggering device is constructed from the infra red transceivers. They are placed about 1cm above the maze floor. Any failure on the electronic triggering devices shall be back up by a manual timing system.
- 3.1.6 The starting procedure of each entry shall be simple and must not offer a choice of strategies to the handler. Pressing a "Start" button/switch once shall activate the micromouse. Throughout the duration of the given time limit, the handler shall not enter any information into the micromouse (such as to change the search strategy, the speed and the maze data).
- 3.1.7 The handler shall be given a setup time of 1 minute to calibrate the sensors, if required. However the handler shall not select any strategies and enter the maze data into the micromouse. The search time shall be started upon the expiry of setup time if the handler still continues to calibrate the sensors. Only **One** handler shall be allowed to operate the micromouse throughout the contest.
- 3.1.8 When the micromouse reaches the destination square, it may stop on its own and remains at the destination or continues to navigate to other parts of the maze or makes its own way back to the starting square. If the micromouse chooses to stop at the destination, it shall be manually lifted out and restarted by the handler. Manually lifted the micromouse out shall be considered as a touch to the micromouse. Therefore a touch penalty shall be added on the scores for all subsequent successful runs.
- 3.1.9 If a micromouse appears to be malfunctioning, the handler may ask the judges for the permission to abandon the run and restart the micromouse from the starting square. The handler shall not require restarting only if the micromouse makes a wrong turn; the judges' decision is final. All handlers have to manage the technical problems within the time limit of 8 minutes given. No re-scheduling of the entry due to technical problems shall be allowed.
- 3.1.10 Before the complete maze is configured, all handlers have to register and cage their entries to the contest officials. Once the entry is caged, no replacement of any parts of the micromouse shall be allowed. Once a micromouse starts its run, no replacement of batteries shall be allowed otherwise considered as a touch to the micromouse and the touch penalty shall be added on for the subsequent scores made by the micromouse.

3.2 The Junior Colleges/Institutes of Technical Education (JC/ITEs) Category

3.2.1 The JC/ITEs Category is opened for all full time students from colleges/institutes. Each college/institute shall be limited to **Four** entries. However, the college/institute may submit the excess entries to the Open Category provided they have more than four entries in this category. Each entry shall not be more than **Six** students and must have its own micromouse. No micromouse shall be shared by any entries neither in this category nor the Open category.

3.2.2 Each entry shall be given a time limit of 8 minutes or 6 crashes to contest on the maze. The micromouse may make as many runs as possible within the time limit provided the micromouse does not crash more than 5 times.

3.2.3 The score of a micromouse shall be obtained by computing a handicapped time for each run as follows:

$$\text{Score of Current Run (reached the destination successfully)} = \text{Run Time} + \text{Search Penalty} + \text{Touch Penalty}$$

$$\text{Search Penalty} = 1/60^{\text{th}} \text{ of the Search Time, in seconds}$$

$$\text{Touch Penalty} = 2 \text{ seconds}$$

For example, if a micromouse, after being on the maze for 4 minutes without being touched, starts a run that takes 20 seconds to reach the destination; the run will have a handicapped time score of $20 + 1/60^{\text{th}}$ of $(4 \times 60 \text{ seconds}) = 24$ seconds. However, if the micromouse has been touched before the run, an additional touch penalty of 2 seconds is added on giving a new handicapped time score of 26 seconds. The run with the fastest handicapped time score for each micromouse shall be the official time score of that micromouse. The accuracy of time score is to the nearest $1/100^{\text{th}}$ seconds.

3.2.4 The run time shall be measured from the moment that the micromouse leaves the starting square until it enters the destination square. A run shall be complete only if the whole of the micromouse enters the destination square.

3.2.5 A computer timing system with electronic triggering devices shall be used for measuring scores of each micromouse. The electronic triggering devices are located at the exit and entry of the starting square and the destination square respectively. The triggering device is constructed from the infra red transceivers. They are placed about 1cm above the maze floor. Any failure on the electronic triggering devices shall be backed up by a manual timing system.

3.2.6 The starting procedure of each entry shall be simple and must not offer a choice of strategies to the handler. Pressing a "Start" button/switch once shall activate the micromouse. Throughout the duration of the given time limit, the handler shall not enter any information into the micromouse (such as to change the search strategy, the speed and the maze data).

3.2.7 The handler shall be given a setup time of 1 minute to calibrate the sensors, if required. However, the handler shall not select any strategies and enter the maze data into the micromouse. The search time shall be started upon the expiry of setup time if the handler still continues to calibrate the sensors. Only **One** handler shall be allowed to operate the micromouse throughout the contest.

3.2.8 When the micromouse reaches the destination square, it may stop on its own and remain at the destination or continue to navigate to other parts of the maze or make its own way back to the starting square. If the micromouse chooses to stop at the

destination, it shall be manually lifted out and restarted by the handler. Manually lifted the micromouse out shall be considered as a touch to the micromouse. Therefore a touch penalty shall be added on the scores for all subsequent successful runs.

- 3.2.9 If a micromouse appears to be malfunctioning, the handler may ask the judges for the permission to abandon the run and restart the micromouse from the starting square. The handler shall not require restarting only if the micromouse makes a wrong turn; the judges' decision is final. All handlers have to manage the technical problems within the time limit of 8 minutes given. No re-scheduling of the entry due to technical problems shall be allowed.
- 3.2.10 Before the complete maze is configured, all handlers have to register and cage their entries to the contest officials. Once the entry is caged, no replacement of any parts of the micromouse shall be allowed. Once a micromouse starts its run, no replacement of batteries shall be allowed otherwise considered as a touch to the micromouse and the touch penalty shall be added on for the subsequent scores made by the micromouse.

3.3 The Open Category

- 3.3.1 The Open Category is opened for all individuals from the universities, the polytechnics, the industry, and the private. Each entry shall not be more than **Six** participants and must have its own micromouse. No micromouse shall be shared by any entries.
- 3.3.2 Each entry shall be given time limit of 10 minutes or 8 crashes to contest on the maze. The micromouse may make as many runs as possible within time limit provided the micromouse does not crash more than 7 times.
- 3.3.3 The score of a micromouse shall be obtained by computing a handicapped time for each run as follows:

Score of Current Run (reached the destination successfully) = Run Time +
Search Penalty + Touch Penalty

Search Penalty = $1/30^{\text{th}}$ of the Search Time, in seconds

Touch Penalty = 3 seconds

For example, if a micromouse, after being on the maze for 4 minutes without being touched, starts a run that takes 20 seconds to reach the destination; the run will have a handicapped time score of $20 + 1/30^{\text{th}}$ of (4 x 60 seconds) = 28 seconds. However, if the micromouse has been touched before the run, an additional touch penalty of 3 seconds is added on giving a new handicapped time score of 31 seconds. The run with the fastest handicapped time score for each micromouse shall be the official time score of that micromouse. The accuracy of time score is to the nearest $1/100^{\text{th}}$ seconds.

- 3.3.4 The run time shall be measured from the moment that the micromouse leaves the starting square until it enters the destination square. A run shall be complete only if the whole of the micromouse enters the destination square.
- 3.3.5 A computer timing system with electronic triggering devices shall be used for measuring scores of each micromouse. The electronic triggering devices are locating at the exit and entry of the starting square and the destination square respectively. The triggering device is constructed from the infra red transceivers. They are placed about 1cm above the maze floor. Any failure on the electronic triggering devices shall be back up by a manual timing system.

- 3.3.6 The starting procedure of each entry shall be simple and must not offer a choice of strategies to the handler. Pressing a "Start" button/switch once shall activate the micromouse. Throughout the duration of the given time limit, the handler shall not enter any information into the micromouse (such as to change the search strategy, the speed and the maze data).
- 3.3.7 The handler shall be given a setup time of 1 minute to calibrate the sensors, if required. However the handler shall not select any strategies and enter the maze data into the micromouse. The search time shall be started upon the expiry of setup time if the handler still continues to calibrate the sensors. Only **One** handler shall be allowed to operate the micromouse throughout the contest.
- 3.3.8 When the micromouse reaches the destination square, it may stop on its own and remains at the destination or continues to navigate to other parts of the maze or makes its own way back to the starting square. If the micromouse chooses to stop at the destination, it shall be manually lifted out and restarted by the handler. Manually lifting the micromouse out shall be considered as a touch to the micromouse. Therefore a touch penalty shall be added on the scores for all subsequent successful runs.
- 3.3.9 If a micromouse appears to be malfunctioning, the handler may ask the judges for the permission to abandon the run and restart the micromouse from the starting square. The handler shall not require restarting only if the micromouse makes a wrong turn; the judges' decision is final. All handlers have to manage the technical problems within the time limit of 10 minutes given. No re-scheduling of the entry due to technical problems shall be allowed.
- 3.3.10 Before the complete maze is configured, all handlers have to register and cage their entries to the contest officials. Once the entry is caged, no replacement of any parts of the micromouse shall be allowed. Once a micromouse starts its run, no replacement of batteries shall be allowed otherwise considered as a touch to the micromouse and the touch penalty shall be added on for the subsequent scores made by the micromouse.

4. CLONING (APPLIES ONLY TO OPEN CATEGORY)

- 4.1 In accordance with the spirit of the competition, clones among the winning entries will only be awarded one prize. Clones will be identified during the "caging" procedure.
- 4.2 Clones are robots with substantially identical physical appearance and working principles.
- 4.3 When in doubt, the decision of the Judges will be final.

OBSTACLE AVOIDANCE ROBOT COMPETITION

1. INTRODUCTION

The object of the contest is to build a small microprocessor-controlled robot vehicle that is able to navigate its way, through an unknown terrain, to the target in the shortest possible time. The target is a yellow coloured square at the center of the quadrant furthest away from the starting point.

The challenge is to design and build a small vehicle capable of fast controlled motion, and provide it with sufficient intelligence to explore and negotiate around obstacles in the shortest possible time to reach the target yellow square. On the first run through the maze, the vehicle can employ a search strategy to navigate through the maze. On subsequent runs, the vehicle would have the capability to record the correct navigation route through the maze and thus be able to perform a 'dash' run through the maze to the yellow square to achieve a faster maze run time.

The purpose of this competition is to provide a technically demanding yet enjoyable problem for the participants.

2. TERRAIN SPECIFICATION

- 2.1 The domain for the obstacle avoidance vehicle competition is a flat area criss-crossed by reflective tape forming a 16 x 16 array of 180mm x 180mm (between centres) squares. An unobstructed border of at least one square width will bound the domain.
- 2.2 The domain floor and its border will be made of wood painted with non-gloss black paint. The squares marking the domain will be constructed with reflective tape (3M Scotchlite reflective tape) of 10mm width.

3. OBSTACLES

- 3.1 The obstacles will consist of rectangular wooden blocks painted with non-gloss white paint. The block can be of any height subject to a minimum of 50 mm. The length and width of the block shall be of a uniform cross-section, either 150 mm x 150 mm or 75 mm x 75 mm. The height is at least 50 mm. If a block is higher than 50 mm, then the horizontal cross-section of the block that is above 50mm can be of any shape provided no part of it extend beyond the base cross-section of 150 mm x 150 mm.
- 3.2 The obstacles will be placed, approximately centrally, within the squares. A minimum passage width of at least one square is guaranteed.
- 3.3 The first move from the start position must be towards the North. This is to facilitate electronic clocking. Obstacles may be placed to ensure this.

4. GENERAL TOLERANCES

The tolerance of the obstacles and domain platform will be within specifications specified in the attached drawings.

5. ROBOT SPECIFICATIONS

- 5.1 There will be no restriction to the length, width or height of the robot vehicle as long as the vehicle fits within the area bounded by 1 square (180mm X 180mm) The vehicle must be fully self contained and not receive assistance from external sources and all parts

of the vehicle must travel to the target. The judge may, however, allow participants to retrieve and restart their vehicles in the event of a collision or other situations when a restart is required.

- 5.2 The vehicle must not attempt to change or damage its environment.
- 5.3 During competition, only the following components are allowed for operation by the competitor
 - One single coloured LED – for indication of power on purposes only. The LED should be either continuously ‘on’ or continuously ‘off’. No blinking of LED or any transmission of coded message is allowed back to the competitor.
 - One power on toggle switch - for connection to the battery power supply.
 - One start/stop button – to start/stop the vehicle before and after each maze run.
 - One reset button – to reset the vehicle CPU.
- 5.4 Any other visual or audible electronics components (e.g. 7-segment LEDs, LCD screens, beeper, LED clusters, etc...) on the vehicle which convey information on navigation strategy or speed mode to the operator is NOT allowed. If there are any of these components used on the vehicle, they must be removed or covered prior to the caging of all entry events. Contravening this rule leads to disqualification.
- 5.5 Starting of vehicle for each maze run is to be activated by one reset button and/or one start button activated by one “press” at a time. Competitors are not allowed to perform double clicks or multiple “presses” on a button in quick succession. Judges will strictly enforce this rule.

6. RULES FOR THE CONTEST

- 6.1 The objective of the competition would be for the robot to reach the target in the shortest time.
- 6.2 Each robot will perform at least two runs within 10 minutes. The timing for a run will start at the instant the judges instruct the participants to start their robots, and end at the instant any part of the robot makes contact with the target yellow square.
- 6.3 All robots must travel on the surface of the domain. Robot vehicles are required to travel within the specified domain and no part of the vehicle must come in direct contact with regions outside the domain. Overhanging within the boundary is allowed.
- 6.4 The use of long probes reaching across obstacles does not constitute "navigate its way through an unknown terrain", and is contrary to the spirit and implied rules of this competition.
- 6.5 No servicing or repairs of any kind are allowed during the 10 minute time allocation to each entry. Should the need arise to replace exhausted battery supplies, permission must be sought from the judges to perform this function. The decision to allow this is left at the discretion of the judges.
- 6.6 The participants will be graded on the fastest 1st run, and on the fastest run. If a vehicle requires a restart, during the first run, it will be disqualified from consideration for the fastest first run prize.
- 6.7 There should be at least 1 clear path (contiguous sequence of full squares) from the starting to the ending position.

- 6.8 Before the start of the competition, entrants are allowed to inspect the layout of the maze to satisfy themselves that all blocks are approximately centrally located on the squares.
- 6.9 Under all circumstances, entrants are not allowed to touch the block obstacles. Should any positional adjustment be made to the block obstacles, these will be performed by the event timers/helpers/judges.

7. CLONING

- 7.1 In accordance with the spirit of the competition, clones among the winning entries will only be awarded one prize. Clones will be identified during the "caging" as well as after the completion of the maze run. The vehicles will not be considered a clone if the search strategies for entries are visibly different through the maze even if the physical appearances are nearly the same.
- 7.2 Clones are robots with substantially identical physical appearance and navigation principles. If the vehicles are only similar in one of these categories, the vehicles are not considered clones.

8. CAGING

- 8.1 All entries must be caged ½ hour prior to the start of the competition. This is to allow the organisers time to set up the maze.
- 8.2 During caging, judges will identify potential clones as well as inspect entries which contravene rules on robot specifications in paragraph 6.

9. JUDGING AND DISPUTES

- 9.1 Decision of the Judges will be final.
- 9.2 Any disputes arising during the competition must be brought up immediately to the judges.

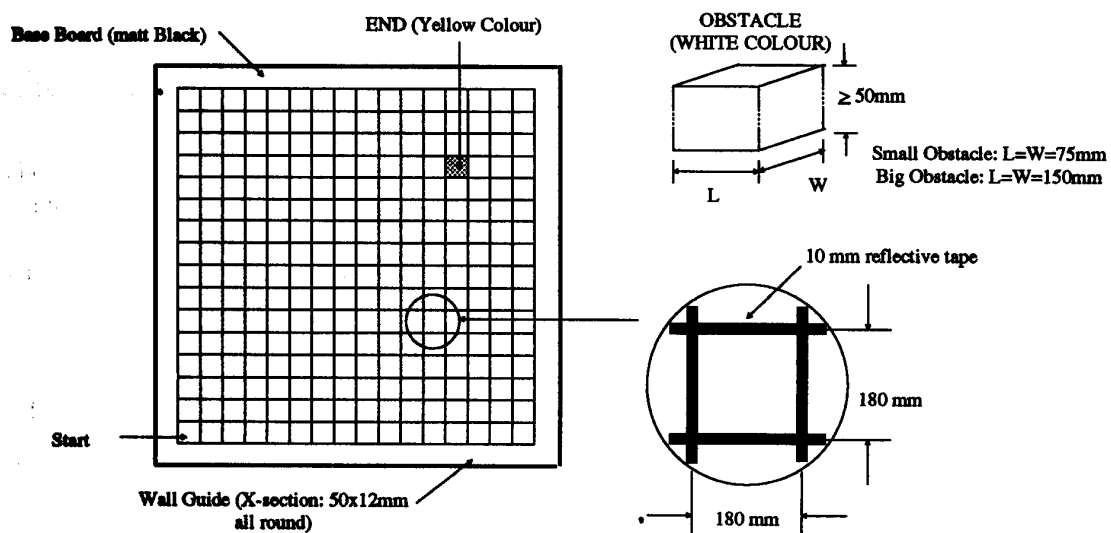

Figure 1: Obstacle Avoidance Robot Terrain

TRASH-BIN DISPOSAL ROBOT COMPETITION

1. OBJECTIVE

1.1 The objective of the competition is to build a self-contained autonomous mobile robot that is able to navigate its way through a network of alley-ways in search of trash-bins which it must collect and dispose of at any one of 3 designated dumping grounds. The performance of the robot is judged on the numbers of trash-bins collected and disposed in a given time duration of 7 minutes.

2. SPECIFICATIONS FOR ALLEY-WAYS

2.1 The alley-ways shall be laid out on a platform by placing pieces of walls along the grids formed by multiples of 18 cm x 18 cm unit squares arranged in a 12 x 12 matrix as shown in Fig 1. The walls for lining the alleyways shall be 5 cm high and 1.2 cm thick. Passageways between the walls shall be 16.8 cm wide. The outside wall shall enclose the entire network of alleyways.

2.2 The start location for the robot shall be at one corner. Disposal centres shall be located next to the remaining 3 corners. There shall be clear passages along the alleyways adjacent to the disposal centres. Where there are no grid lines shown in the vicinity of the disposal centres, there shall be no walls. (See Fig 1) The start square shall have walls on 3 sides. The starting square orientation shall be such that when the open end is to the "north", outside walls are on the "west", and "south".

2.3 Each of the disposal centres shall be a box with a top opening. The internal dimensions shall be 34.8 cm x 34.8 cm x 5 cm (length x width x height). The thickness of the sidewalls shall be 1.2 cm (See Fig 2). The disposal centre shall be located such that the top edges are at the same level as the top of the alley-way walls and one side flushes with the side of the alley-way enclosure wall.

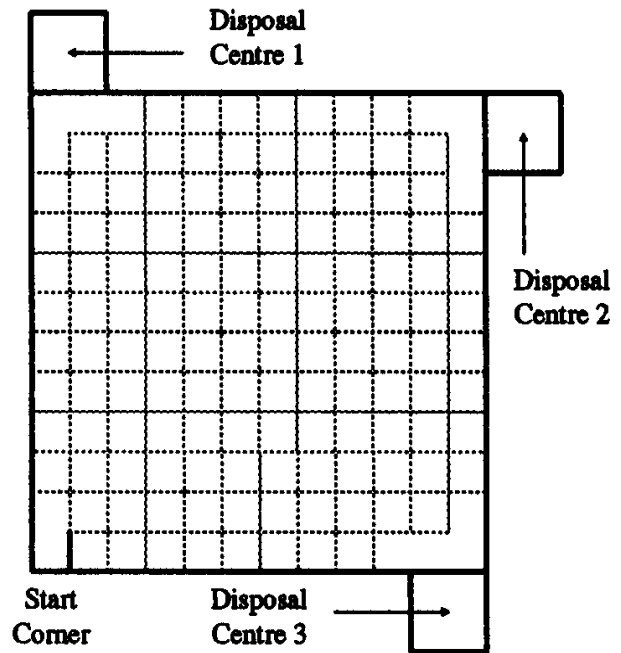

Figure 1: Start and Disposal Points and Grid Lines for Alley

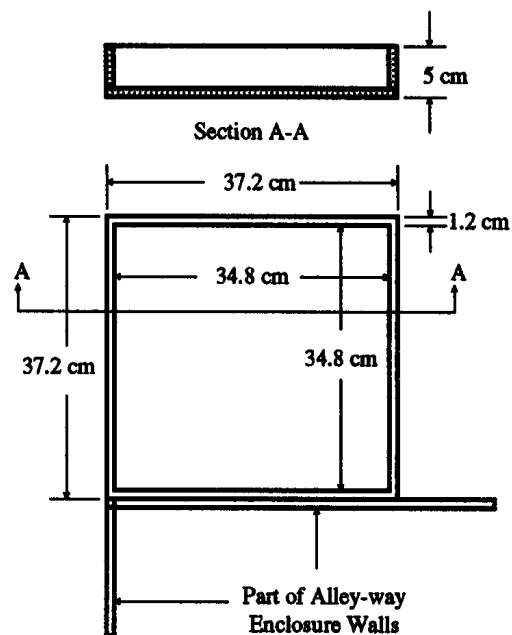

Figure 2 Disposal Centre Dimensions

- 2.4 The sides and top of the alleyway walls shall be white. The floor of the platform shall be made of wood and finished with a non-gloss black paint. The coating on the top and sides of the walls shall be selected to reflect infrared light and the coating on the floor shall absorb it.
- 2.5 Small square posts, 1.2 cm x 1.2 cm x 5 cm high, at the 4 corners of each unit square are called lattice points. The alleyways shall be constituted such that there is at least 1 wall touching each lattice point. The distribution of trash-bins in the alleyways shall be such that there shall be at least 1 clear path to any 1 of the disposal centres. A sample layout is given in Fig 3.

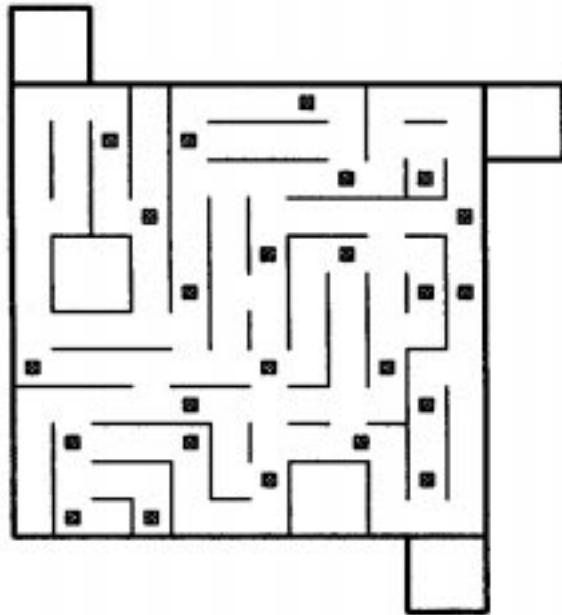

Figure 3: Sample AlleyWay Configuration with Trash-Bins

3. TRASH-BIN SPECIFICATION

- 3.1 The trash-bin shall be a 5-cm high dumb-bell shaped wooden post with a 1.2 ± 0.2 cm diameter cylindrical body and 2.5 cm x 2.5 cm x 1 cm rectangular ends. (See Fig 4). It shall be painted red on all sides. The weight of the trash-bin shall not exceed 15 grams.
- 3.2 The trash-bin shall be placed free standing at the centre of a unit square. The orientation shall be such that the sides of the trash-bin rectangular ends are parallel to the walls of the alleyway.

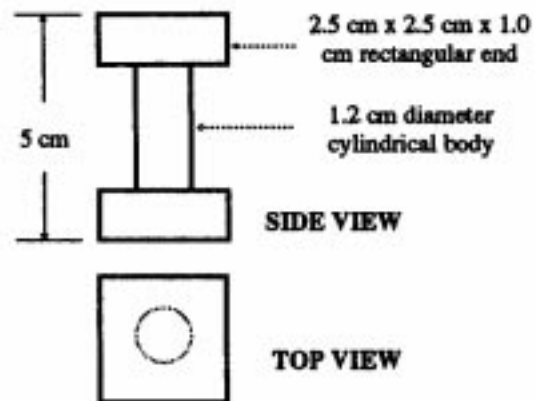

Figure 4: Trash-Bin Dimensions

4. ROBOT SPECIFICATION

- 4.1 The length and width of the robot shall be restricted to a square region of 25 cm x 25 cm before it is out of the start square. There is no restriction to the dimensions of a robot which changes geometry after it has left the start square. There is no restriction on the height of the robot.
- 4.2 The robot must be completely self-contained and must receive no outside help.
- 4.3 The methods of alleyway wall sensing and trash-bin detection, collection and disposal are at the discretion of the builder; however, the robot must not exert a force on any wall or trash-bin likely to cause damage. The method of propulsion is at the discretion of the builder, provided the power source is non-polluting.
- 4.4 The robot shall not leave anything behind while negotiating the alleyways.

- 4.5 The robot shall not jump over, climb, scratch, damage or destroy the walls of the alleyways and disposal centres.

5. RULES FOR THE CONTEST

- 5.1 The basic function of the robot is seek out and collect as many trash-bins as possible which are placed along alley-ways and to dispose of them in any of 3 disposal centres within the given performance time period. The disposal strategy is left to the robot builder. For example, the trash-bins can be collected and disposed of one at a time, or the robot could collect and dispose several trash-bins at a time.
- 5.2 A trash-bin is considered disposed if more than half of its body is within the collection centre. Any trash-bin unsuccessfully disposed but resting on top of the collection centre wall(s) shall be removed and discarded only at the end of the robot's performance. Any trash-bin unsuccessfully disposed and has fallen onto the floor shall be removed and discarded when the robot subsequently crashes and has been retrieved by its handler. (See also clause 5.5)
- 5.3 Each robot will be given a maximum of 6 attempts or 7 minutes to perform its tasks. In other words, a robot will only be allowed 5 crashes within the 7-minute time limit. The competition time for each robot starts from the moment the robot is picked up from the caging area.
- 5.4 The robot will be judged on the number of trash-bins disposed in the designated disposal centres within the time duration given and if it is able to dispose of all the trash-bins, then the time taken to do so will be the main criterion. In the event that 2 or more robots that have disposed the same number but not all of the trash-bins within the time given, then the number of trash-bins collected but not disposed, including those still remaining in the robot at the instance of the expiry of the competition time given shall be used as the next level of performance criterion. A third level criterion will be the number of times the robot had to be retrieved and restarted during the performance period. If there is still a tie, then the judges will decide on the better robot based on other criteria solely at the discretion of the judges.
- 5.5 The starting procedure of the robot should be simple and must not offer a choice of strategies to the handler. The robot shall be started by pressing a "start" button once. The robot shall be placed at the start square and started by the handler under the officials' instructions. Throughout the duration of the robot's performance, the handler shall not enter any information into the robot.
- 5.6 In the event that a robot crashes into the alleyway wall(s) and loses it bearing, then it is retrieved by the handler. The robot shall be re-started in a start location (one of the corners), and the size of the robot must be restricted to 25 cm x 25 cm at the start location (consistent with para. 4.1). The trash-bins that have been displaced shall be removed and discarded by contest officials before the robot is re-started. Any trash-bins collected and properly held by the robot in its collection mechanism shall also be discarded but kept aside for a fourth level of arbitration criterion in event of a tie as provided for in paragraph 5.3. The chief judge (who shall be the rules committee chairman) in consultant with the other judges, if any, determine whether a trash-bin has been "collected and properly held in the collection mechanism". In any event, any trash-bin that has been discarded shall not be available for collection and disposal by the robot when it is re-started.

- 5.7 If a robot appears to be malfunctioning, the handlers may ask the judges for permission to retrieve and restart the robot from the start square. A robot may not be restarted merely because it has taken a wrong turn - the judges' decision is final.
- 5.8 If a robot elects to retire because of technical problems, the judges may, at their discretion, permit it to do a fresh performance later in the contest but with a reduced time duration of 6 minutes. The result of the robot's second attempt shall be its official performance and its earlier attempt shall be null and void even if eventually the result of the first attempt is better than its second attempt. Also there shall be no changes made to the program, seek strategies and collecting method/mechanism when the robot is being repaired except for batteries and identical spare parts. This permission is likely to be withdrawn if the programme is full or behind schedule.
- 5.9 Before the alleyway configuration and trash-bin placements are unveiled, the robots must be accepted and quarantined by the contest officials, and no replacement of any parts of the robot. Once the robot has started, no replacement of batteries shall be allowed during the full duration of its performance.

6. CLONING

- 6.1 In accordance with the spirit of the competition, clones among the winning entries will only be awarded one prize. Clones will be identified during the "caging" procedure.
- 6.2 Clones are robots with substantially identical physical appearance and working principles.
- 6.3 When in doubt, the decision of the Judges will be final.

CAT AND MOUSE - THE SCAVENGERS

1. OBJECTIVE

The nature of this contest is similar to the Pac-man computer game. It consists of two robots, namely Tom-the-Cat and Jerry-the-Mouse. These two robots have to work together to collect food on the maze. Tom's mission is to bring fish back to the cat's home. Jerry's mission is to bring cheese back to the mouse's home.

Tom and Jerry are to pick up their own food. However they may communicate with each other to help complete the food scavenging as fast as possible. For example, if Tom meets a piece of cheese, it can signal the location of this cheese to Jerry, who will remember to pick up this cheese. Similarly, Jerry may inform Tom of any fish seen on the maze. In the event that a wrong food pallet is collected, additional time penalty will be added to the total time.

The game is completed when all food pellets have been collected, the time allotted is up, or if the handlers request for the clock to be stopped.

2. CAT AND MOUSE SPECIFICATIONS

- 2.1 Any form of mobile robots (wheeled or legged) are acceptable for this competition.
- 2.2 The length and width for Tom and Jerry shall be restricted to a square region of 25 cm x 25 cm. There is no restriction on the height of the robots.
- 2.3 The robot has to be COMPLETELY autonomous.
- 2.4 The Cat and Mouse should not leave anything behind while negotiating the maze.

3. TERRAIN SPECIFICATION

- 3.1 The domain is a flat area criss-crossed by reflective tape forming a 16 x 16 array of 180mm x 180mm (between centres) squares.
- 3.2 The domain floor and its border will be made of wood painted with non-gloss black paint. The squares marking the domain will be constructed with reflective (3M Scotchlite reflective tape) of 10mm width.
- 3.3 There are 2 Home positions marked by the squares located at diagonal corners of the maze. One Home square for Tom-the-Cat and the other for Jerry-the-Mouse.
- 3.4 The tolerances of the domain platform will be within the specifications specified in Figure 1.

4. FISH AND CHEESE SPECIFICATION

- 4.1 The Fish and Cheese shall be flat pellets of 0.5mm thickness, with square (fish) and round(cheese) shapes. They are made of unfinished galvanised steel sheets (0.5mm) which can be picked up by magnet. A sample pellet will be given to each represented institution.
- 4.2 The Fish and Cheese are to be placed at any corner of the squares formed by the tracks. The gap of separation of the track and the Fish-edge or Cheese-edge, should be 10 mm. See Fig.2.

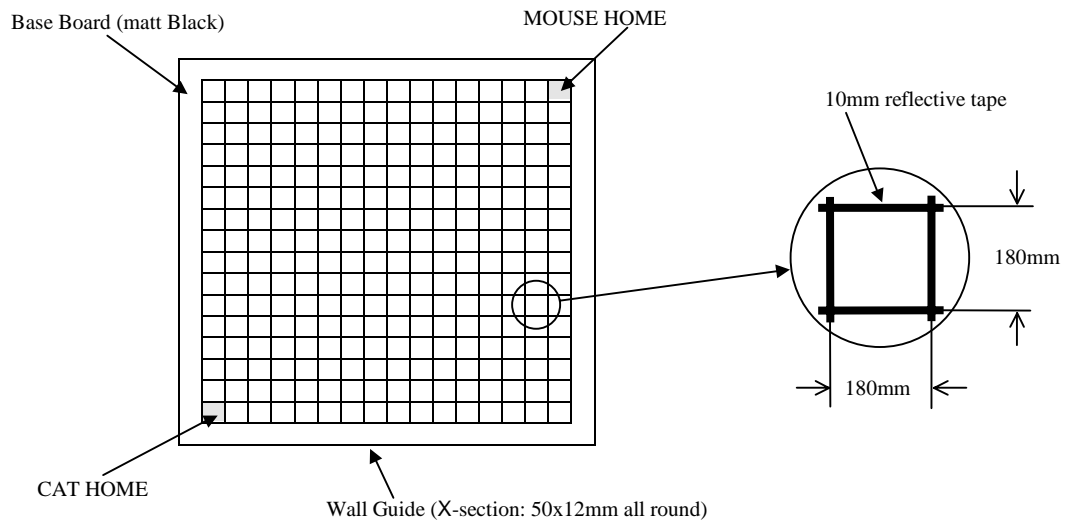

Figure 1: Cat and Mouse - The Scavengers' Terrain

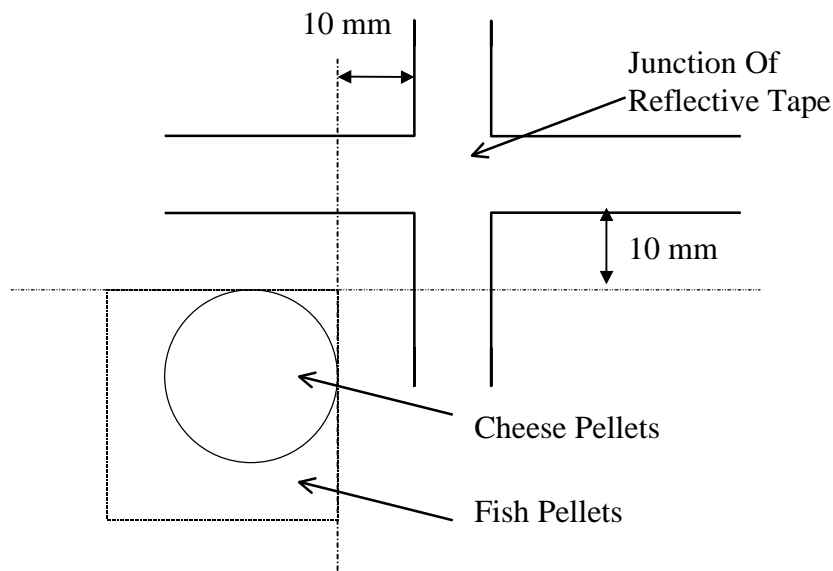

Figure 2: Cat and Mouse - Placement of Food Pellets

- 4.3 At any square, there may be more than one food pellet placed. However, at any intersection of the tracks, there will not be more than one food pellet placed.
- 4.4 The Fish pellet dimension is a square of 3 cm x 3 cm.
- 4.5 The Cheese pellet dimension is a round disk of diameter 2 cm.

5. RULES FOR THE CONTEST

- 5.1 Each run shall be subjected to a time limit of 8 minutes on the maze. Within this time limit, Tom and Jerry may make as many runs as possible.
- 5.2 There will be 5 to 10 pieces of Fish and 5 to 10 pieces of Cheese on the maze.

- 5.3 The robot starts from Home position. It may start in any orientation within the Home square.
- 5.4 Once the robots are out of the Home position, it can only go back to the respective homes with a food pellet. The robot is considered to have returned to Home position when any part of the robot is inside the Home square.
- 5.5 Tom may only deposit Fish in the Cat's home. Jerry may only deposit Cheese in the Mouse's home. The deposit of food into Home position means that the final resting position of the food must be within the Home square and not touching the tape.
- 5.6 Once each food pellet is brought and dropped at Home position, participants may reposition the pellets at the border area outside the maze. This is to prevent the food pellets from cluttering the homes.
- 5.7 The robots must pick up and bring back only one piece of food at each time. While holding a pellet, the robot can touch another pellet provided the second pellet does not touch the reflective tape or go beyond the square grid.
- 5.8 The robots are NOT allowed to touch each other. Once they touch each other while manoeuvring the domain, both robots are considered to have crashed.
- 5.9 The game ends when :
- All food pellets has been collected.
 - Time of 8 minutes is up.
 - Participant request to stop the game(clock)
- 5.10 Judging Criteria :
- The team which is able to collect all correct food pellets in the shortest time shall win.
- In cases where none of the teams have completed collecting all correct food pellets, the following penalties will be added to the time at which the clock is stopped.
- Penalty of 2 minute to be given for each food pellet not taken home.
 - Penalty of 30 seconds to be given to each wrong food pellet taken home.
 - Penalty of 30 seconds to be given for returning to Home without food pallet.
- 5.11 A robot is required to restart from home position, if the following occurs during the competition:
- robot has crashed.
 - robot has dropped it's food outside it's home.
 - robot has picked up more than one food pellet at a time.
- 5.12 If the robot is holding a food pallet when i) to iii) occurs the food pallet will not be returned to its original position and will be taken out of the maze.
- 5.13 If the robot is not successful in collecting any food pallets, no scores will be computed.
- 5.14 In the event that a food pallet is moved and it touches the reflective tape, the pallet is forfeited and will be removed.

6. CLONING

- 6.1 In accordance with the spirit of the competition, clones among the winning entries will only be awarded one prize. Clones will be identified during the "caging" as well as after the completion of the run. The vehicles will not be considered a clone if the collection strategies for entries are visibly different through the maze even if the physical appearances are nearly the same.
- 6.2 Clones are robots with substantially identical physical appearance and game strategies. If the vehicles are only similar in one of these categories, the vehicles are not considered clones.

7. CAGING

- 7.1 All entries must be caged ½ hour prior to the start of the competition. This is to allow the organisers time to set up the maze.
- 7.2 During caging, judges will identify potential clones as well inspect entries which contravene rules on robot specifications.

8. JUDGING AND DISPUTES

- 8.1 Decision of the Judges will be final.
- 8.2 Any disputes arising during the competition must be brought up immediately to the judges.

ROBOT SOCCER COMPETITION

INTRODUCTION

The objective of the robot soccer is to build a team of robots to play 3-a-side football against an opponent robot team. Each robot soccer team shall setup a global vision system, which is above the football field, to keep track of their robots and ball positions. A host computer may process the vision information and send the motion commands to soccer robots through radio frequency communication.

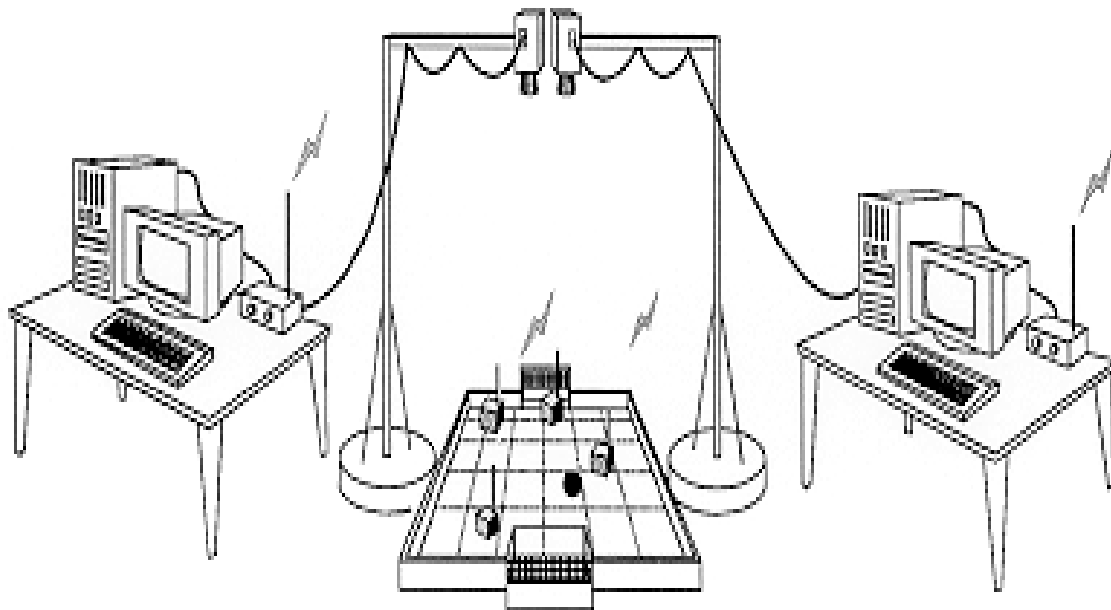

The robot soccer designers have to take up the challenges such as to identify their own robots, the ball, and the opponent robots through the vision information, and to establish a reliable protocol for the radio frequency communication. They need also to implement various strategies among the team robots for attacking and defending, and to manage the fouls that comprise of free ball, penalty kick, goal kick, and free kick.

1. THE FOOTBALL FIELD SPECIFICATIONS

1.1 The dimensions of the football field is 150cm (length) x 130cm (width) x 5cm (height). The whole field shall be made of wood and the surface texture shall be similar to the table-tennis table. The floor of the field is painted matted black and the walls that constitute the height are in white.

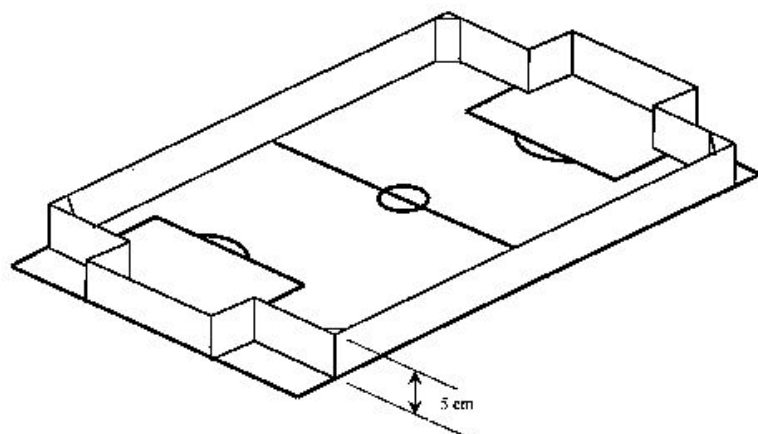

1.2 The markings on the football field are shown in figure 1. All markings are white in color. The thickness of marking for the half field line, the goal area box outlines, the half field circle, and the goal kick area arc outlines is 3mm. On the field, the four corners shall be fended off by 7cm to avoid the ball getting stuck at each corner. The cross markings for the penalty kick, free kick, and the free ball shall be 1mm thick and 5mm long. The solid circle markings for free ball positions are in white and of diameter 2mm.

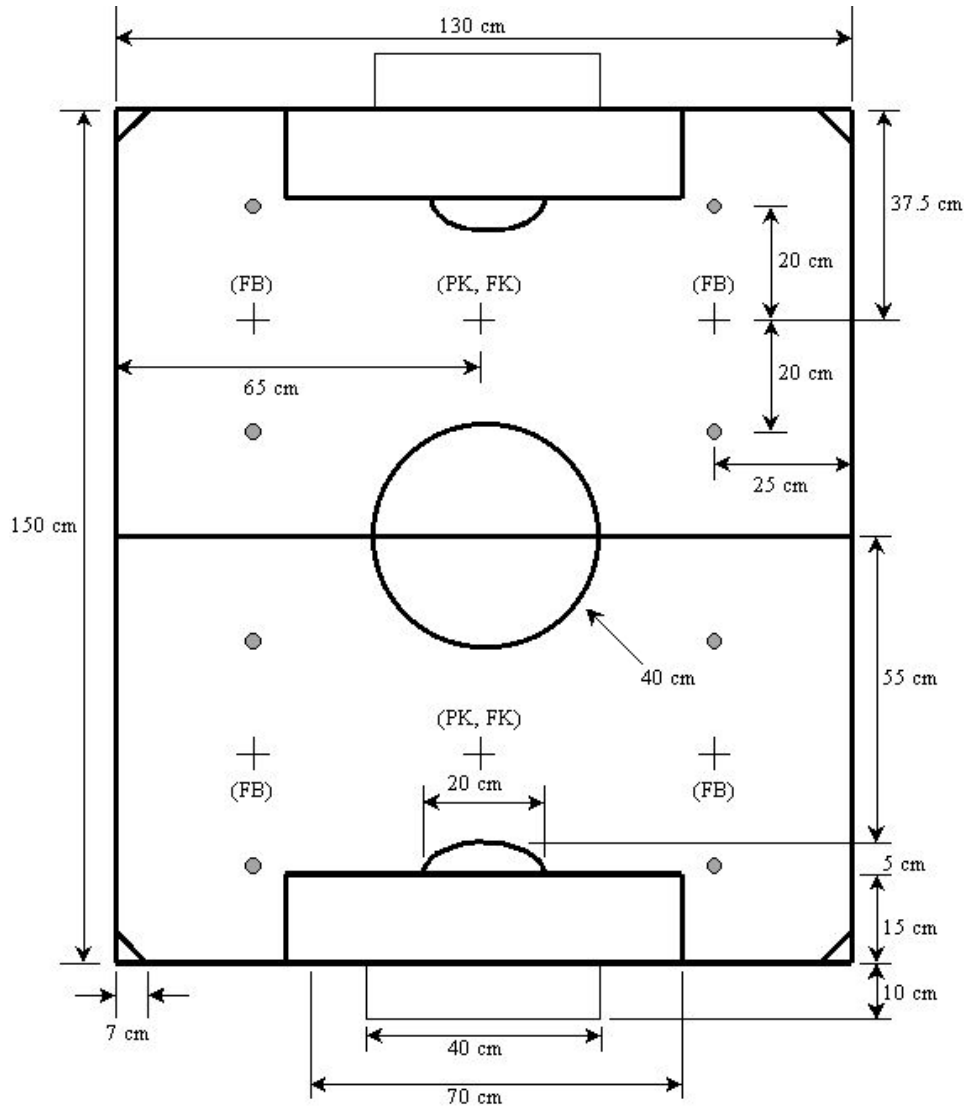

Figure 1: The dimensions of the Football Field

1.3 The goal shall be 40cm wide. No posts and net shall be used to avoid obstruction to the global vision system

1.4 The football field shall be located indoor and the luminous level shall be about 700 lux.

2. Football Specification

An orange golf ball shall be used as the football. Its diameter is 42.7mm and the weight is 46g.

3. Robot Specifications

- 3.1 The dimension of each soccer robot shall be 7.5cm (width) x 7.5cm (length) x 7.5cm (height). The robot height shall not include the antenna.
- 3.2 Each robot shall put on a costume and the dimension shall not exceed 8cm (width) x 8cm (length) x 8 cm (height). The costume shall not cover the antenna.
- 3.3 A color pad shall be printed or stuck on the top of the costume for team identification. Yellow and blue shall be used for team colors. The officials shall leave the two competing teams to decide which color to represent their robots. Otherwise the selection of team color shall be done by the toss of coin.
- 3.4 The dimension of color pad shall be not less than 12.25cm^2 or 3.5cm (length) x 3.5cm (width). The color pad shall not exceed the top area of the costume. A team may use more than one color for the robot identification provided the other color shall not be the same color as the ball (orange) or the opponent team color (yellow or blue).
- 3.5 All robots shall be fully autonomous (no external power source and manual control). The communication among the team robots and the host computer shall be through the radio frequency (rf). Each robot team shall accommodate two frequency channels so that no team shall share the same frequency channel with the opponent team.
- 3.6 Any robot may install a shooter or catcher but the overall robot size shall not exceed its allowable dimension (7.5cm (length) x 7.5cm (width) x 7.5cm (height)) when the shooter or catcher is activated. No team robot (except goalkeeper) shall be allowed to cover the ball more than 30% (neither from the side or top) when it occupies the ball. The goalkeeper robot shall hold and cover the ball completely only within the specified goal area.

The diameter of the ball $D = 42.7$ mm

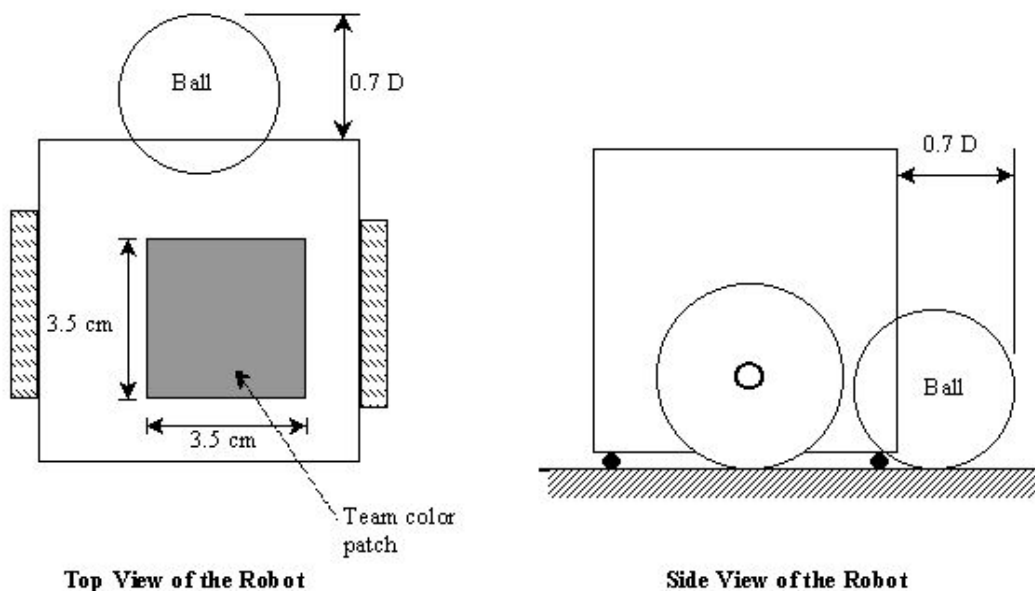

- 3.7 Whenever the referee whistles, all robots shall stop either by themselves or through the commands sent by the host computer.

4. Global Vision System Specifications

- 4.1 Each team shall be allowed to use their own vision system and camera for their robots. They may use their own camera stand provided the height of the camera is 2 meters or

above with respect to the floor level of the venue. The official camera stand shall be moved away if both teams provided their own stands. If both teams are not able to settle on their stand placements, the official stand shall be used.

- 4.2 The height of the official camera stand is 2 meters above the floor level of the venue. There shall be only **One** beam across the center of the football field supported by the camera stand. Either team may mount their camera on the left or the right side of the beam. The organizer shall leave the two competing teams to settle the camera positions. Shall there be any disagreement, the organizer shall decide the camera positions for both teams by the toss of coin.

5. Host Computer Specification

Each team shall be allowed to use more than one computer (any computer) as the host computer. The host computer may send any information to the soccer robots through the rf communication while the match is in progress. But the host shall not control the motion of robots directly through the host keyboard or joystick. However the soccer strategies can be modified through the host computer while the match is paused.

6. Rules for the Competition

- 6.1 All participating teams shall compete among each other through a mixture of the league and knock out systems. The final decision for the competition shall be announced upon the closure of the registration.
- 6.2 The duration of a match for two competing teams shall be divided into two periods. Each period shall last for 5 minutes, excluding the time for robot substitution, timeout, and any fouls encountered. A timekeeper shall be appointed to stop the official clock when all these happened. There is a **half time** break of 10 minutes between the two periods.
- 6.3 Any team shall be given an additional 5 minutes if they are not able to start the match or resume the match upon the expiry of the half time break. The team shall be considered to have lost the match if they are still unable to play after the additional 5 minutes is over.
- 6.4 Any team shall be given 3 chances to substitute faulty robots throughout the match. These chances shall be used either in the first period or the second period or both but the total substitutions shall not exceed 3 times. However, there will be no limits to the number of substitutions during the half time break. When a team requires a substitution, the handler shall notify the referee by calling '**substitution**' and the referee shall stop the match only when a foul or free ball situation is encountered.
- 6.5 Any team shall be given 2 time-outs throughout the match that includes the first period and the second period. When a team requires a time-out, the handler shall notify the referee by calling '**time-out**' and referee shall stop the match only when a foul or free ball situation is encountered.
- 6.6 Each team shall be allowed **two** members to handle the match. One of the members is to operate the host computer. Another is to place the robots in the football field during the start of the match period, the substitution, the time-out, and when any foul is encountered. The rest of members shall keep away from the football field area. A referee shall be appointed by the official to blow the match. He/she shall be a neutral person and is not a member of the competing teams.
- 6.7 When a match is about to start, the referee shall decide which home field for the two competing teams and which team to kick off first by the toss of coin. Both teams shall

settle the team color (yellow/blue) and the rf channel by themselves before seeking the referee's decision. The kick-off team shall place their robots in their own field first, followed by the opponent team. A kick-off robot shall be placed in the opponent field (within the center circle) for the kick off.

6.8 The ball shall be placed by the referee at the center of the center circle for the kick off. The kick-off team shall pass or kick the ball back to its own field area first. If a kick-off team fails to complete this task for twice, a goal kick shall be awarded to the opponent team. The defending team has to wait for the kick-off team to touch the ball before their robots start to move.

6.9 A sample for the robot kick-off positions is given below

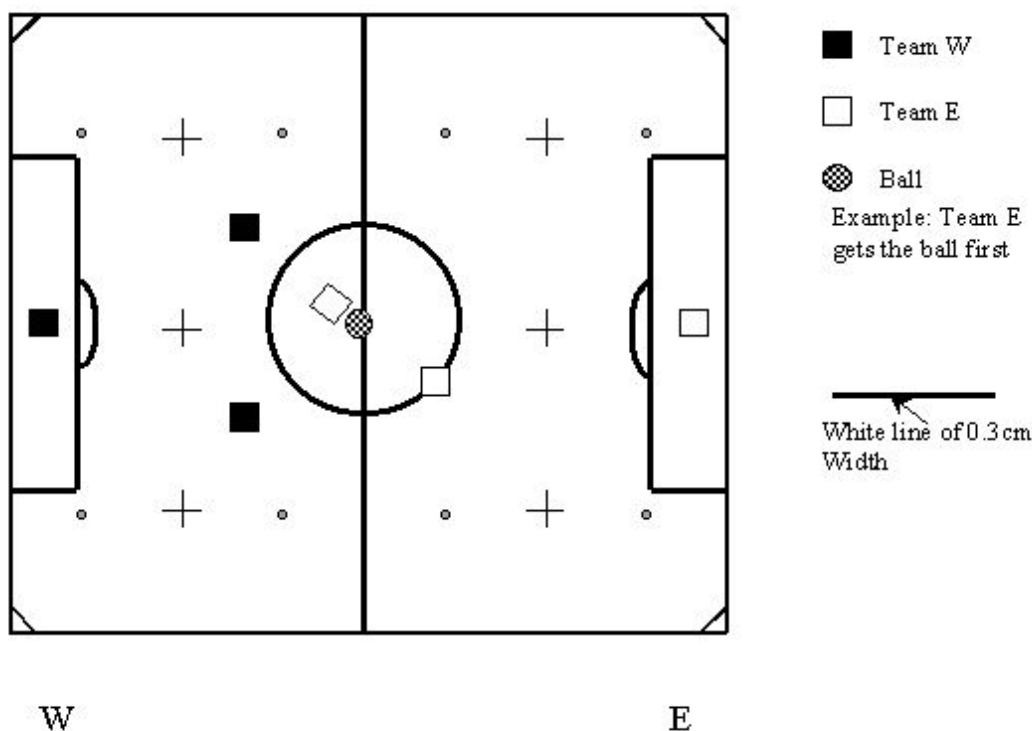

6.10 The robot kick-off positions shall be applied after a goal is scored by a competing team. The loser shall be the kick-off team.

6.11 After the half time break, both competing teams shall exchange their home field before the kick-off.

6.12 A team shall be considered to have scored a goal if its robot passes/kicks the ball across the goal line. The number of goals scored shall determine the match winner. If there is a draw after the second period, the match shall continue for an additional 3 minutes under the 'sudden death' rule that is the match winner is determined by the team which scores the goal first within the additional 3 minutes. During the additional 3 minutes match, there shall be no changing of field between the two teams.

6.13 If a draw still persists after the additional 3 minutes has expired, the match winner shall be determined by penalty kicks. Each team shall be given 3 chances. Any team robot shall be the penalty kicker. The referee shall place the ball at the penalty kick marking. The kicker shall place the robot behind the ball first and the opponent goalkeeper robot shall be placed along the goal line later. After the referee's whistle, the goalkeeper may move freely within the goal area box and the kicker shall kick the ball. A penalty kick shall be completed, if:

1. the ball crosses the goal line,
2. the goalkeeper catches the ball in the goal area box,
3. the ball comes out from the goal area,
4. 30 seconds have passed after the referee's whistle.

If the score is still a draw after the 3 penalty kicks from each team, the penalty kick shall proceed on a one-to-one basis until a match-winner is decided. A goal scored shall be disqualified if the kicker pushes the goalkeeper and the ball across the goal line.

6.14 There shall be 8 fouls situations, they are

- 6.14.1 Any robot shall not adopt pushing away the opponent robots (except the opponent goalkeeper) as the match strategy. The referee shall award a free kick to the opponent team whenever this happens. However the referee shall allow both competing robots to push each other indirectly through the ball or if the push (directly or indirectly) does not affect the play of the match.
- 6.14.2 Any attacking robot shall not be allowed to push the defending goalkeeper robot and the ball to score a goal. Any goal scored under this circumstance shall be disqualified. The referee shall award a goal kick to the goalkeeper.
- 6.14.3 The attacking team shall not send any robot to block the defending goalkeeper robot from attending the ball as the match strategy. If this happens, the referee shall award a goal kick to the goalkeeper.
- 6.14.4 An attacking robot shall not stay within the opponent's goal area box for more than 10 seconds. The robot has to retrieve from the goal area within 10 seconds and then re-strike again if necessary. The referee shall award a goal kick to the goalkeeper if the attacking robot stayed longer than 10 seconds. Under no circumstances shall two attacking robots be allowed to stay in the opponent's goal area. Whenever this happens, the referee shall award a goal kick to the goalkeeper immediately. An attacking robot shall be considered to be within the opponent's goal area if more than 50% of its body is inside the goal area.
- 6.14.5 Only the goalkeeper shall be allowed to stay within its own goal area box. Any additional team robots, besides the goalkeeper; shall not stay in the goal area for more than 10 seconds otherwise the referee shall award a penalty kick to the attacking team. However, the additional team robot (other than the goalkeeper) may be allowed within the goal area provided the robot does not perform the defense or affect the play of the match. The referee shall be the judge of the situation.
- 6.14.6 A goalkeeper shall not hold/cover the ball for longer than 10 seconds in the goal area (2 chances) otherwise the referee shall award a free kick to the opponent team.
- 6.14.7 A goalkeeper shall not hold/cover the ball outside the goal area otherwise the referee shall award a free kick to the opponent team.
- 6.14.8 If a ball does not move for more than 10 seconds, the referee shall award a free ball to both teams.

6.15 Samples of the robot placements for various kicks are given below,

- 6.15.1 Free Kick – The ball shall be placed at the free kick marking by the referee. Both defending robots shall be placed along the front line of the goal area box. One of the attacking robot shall be placed behind the ball and the other shall be placed

behind the robot taking the free kick. The opponent team shall place their robots first.

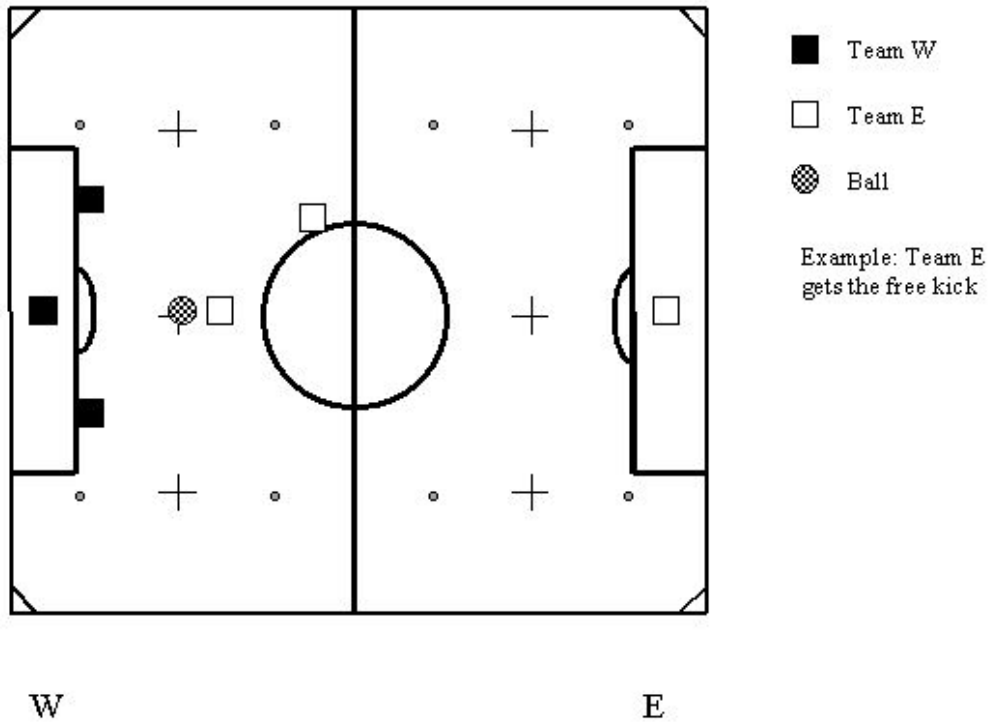

6.15.2 Penalty Kick – The ball shall be placed by the referee at the penalty kick marking. The defending goalkeeper robot shall be placed along the goal line. An opponent robot taking the kick shall be placed behind the ball. All other robots shall be placed in the opponent field behind the centerline. The defending team shall place their robot first. After the referee’s whistle, all robots shall wait for the penalty kicker to touch the ball before they are allowed to move freely.

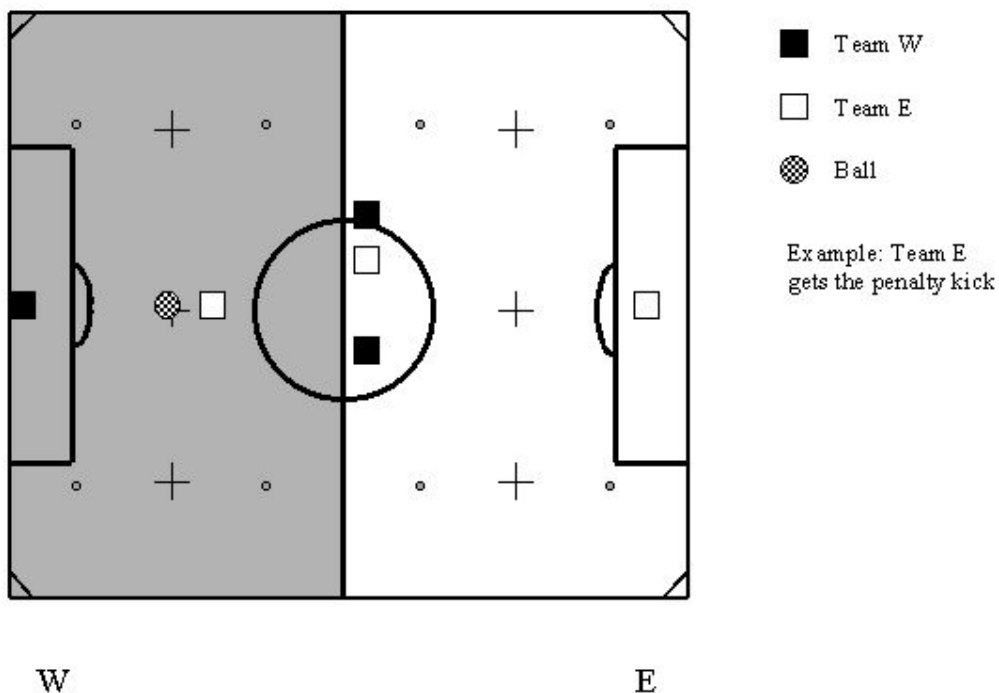

6.15.3 Goal Kick – The goal kicker team can place the ball at any position within the goal area box or along the goal area box lines. The goal kicker team shall place the robot freely in the field first. The opponent team shall not place their robots beyond the free ball markings on the goal kicker’s home field.

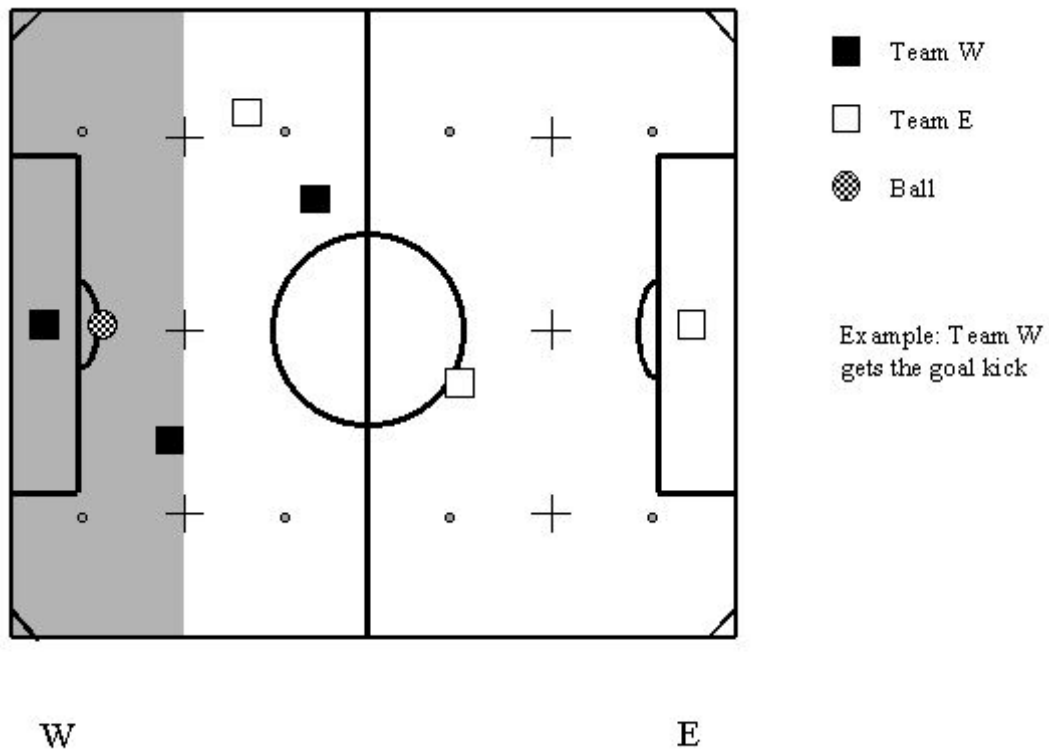

6.15.6 Free Ball – There are 4 free ball placement markings provided in each quarter of the football field for which to place the ball for free ball situations, depending on which quarter the ball is in when the whistle is blown. The referee shall place the ball at the quarter’s free ball markings. The defending team shall place their robots first. Both other team robots shall be placed outside the quarter that the free ball is to be kicked.

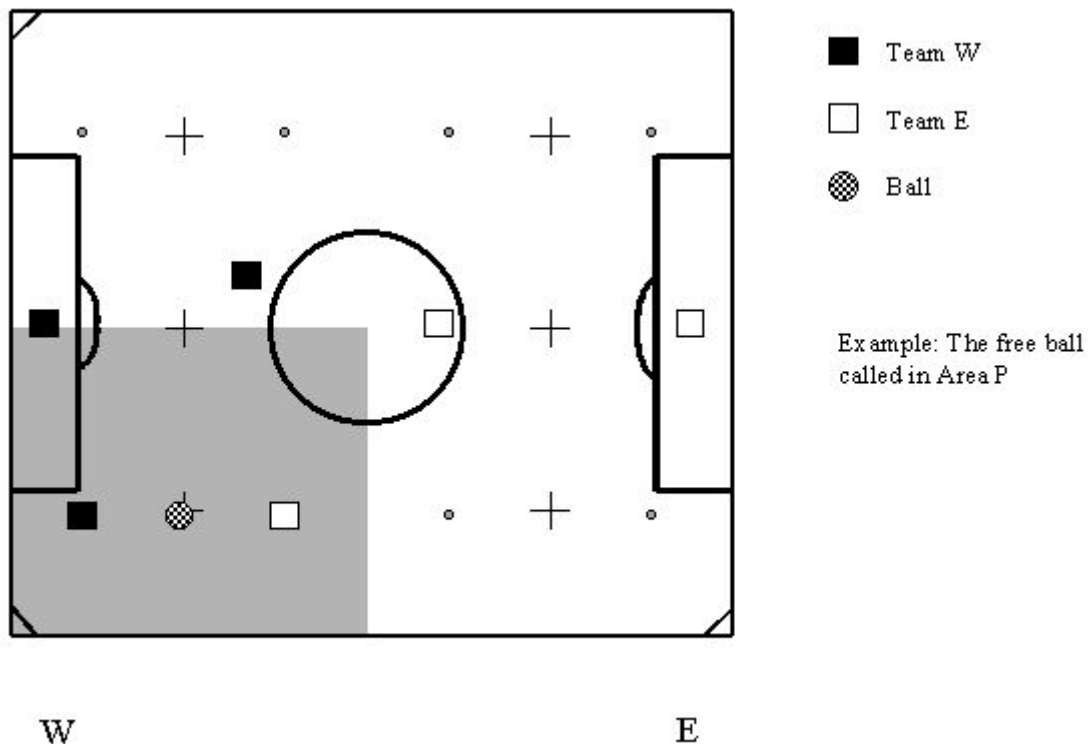

SCHOOLS' ROBOTIC GAMES - SMART DELIVERY ROBOT

1. OBJECTIVE

To build a microcontroller – controlled autonomous robot to trace a path, through obstacles, travel across a pivoted platform to deliver a ball to a target tray and return to the starting line.

2. JUDGING CRITERIA

The shortest time to complete the task successfully.

3. RULES AND REQUIREMENTS

- 3.1 The robot is to be controlled by an on-board microcontroller and powered by 6 AA size batteries. The body of the robot should mainly be made up of LEGO parts.
- 3.2 The maximum size of the vehicle is 20 cm long and 15 cm wide.
- 3.3 The path is made up of light color reflective tape of 50 mm wide with black background.
- 3.4 The robot will start from a starting frame at one end of the track and carry a table tennis ball. It is to trace along a guide path and travel around several obstacles to reach a pivoted platform. It is to go over the platform, deliver the ball into a tray located at the far end of the track and return to the starting frame following the same path.
- 3.5 The robot is given 10 minutes to produce its best result.
- 3.6 A penalty of 5 seconds will be added for every adjustment made during each run. Only 3 adjustments are allowed for each run. Dropping of ball during the run is considered as an unsuccessful run.
- 3.7 Permission may be granted for 1 recess (10 minutes) and it carries a penalty of 3 minutes on the competition time.

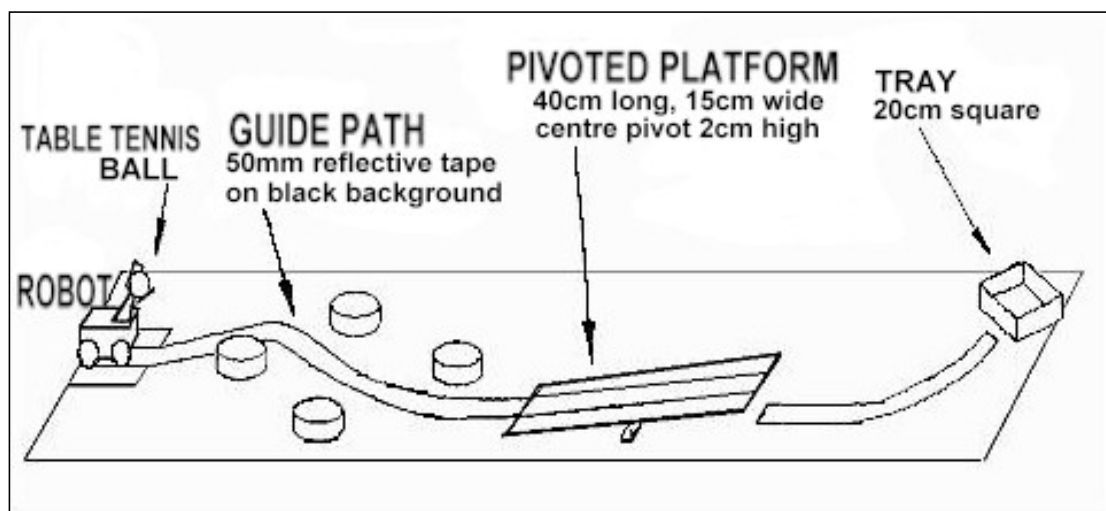

VERSION NOTES (V4.2)

1. DESCRIPTION

This section lists the revisions made to the Rules in the current version as compared to the previous release. The list will only mention the specific sections revised and the pages the sections were located in the current rulebook, but not the detailed contents.

2. CURRENT REVISION (DATED 20 MARCH 2000)

No.	Event Name	Section	Page	Brief Description
1	Schools' Robotic Games	whole	48 -	Update of Rules

3. CURRENT REVISION (DATED 16 DECEMBER '99)

No.	Event Name	Section	Page	Brief Description
1	Robot Soccer Competition	whole	40 -	Update of Rules

4. PREVIOUS REVISION (DATED 10 DECEMBER '99)

No.	Event Name	Section	Page	Brief Description
1	Micromouse	3.*		Inclusion of rules for the 3 sub categories.