

NATIONAL UNIVERSITY OF SINGAPORE  
RESIT EXAMINATION FOR THE DEGREE OF B.ENG

**ME4245/EE4304 ROBOTICS**

April/May 1996 Time Allowed: 2 Hours

---

**INSTRUCTIONS TO CANDIDATES**

1. This examination paper contains four (4) questions, and comprises six (6) pages.
2. Answer all questions in the paper.
3. All questions carry equal marks.
4. This is an open-book examination.

- Q1 (a) In Figure 1, the y axis of Cartesian Frame A is parallel to the z axis of Frame U. Determine the homogeneous transformation matrix  ${}^U\mathbf{T}_A$  that describes the position and orientation of Frame A in Frame U.

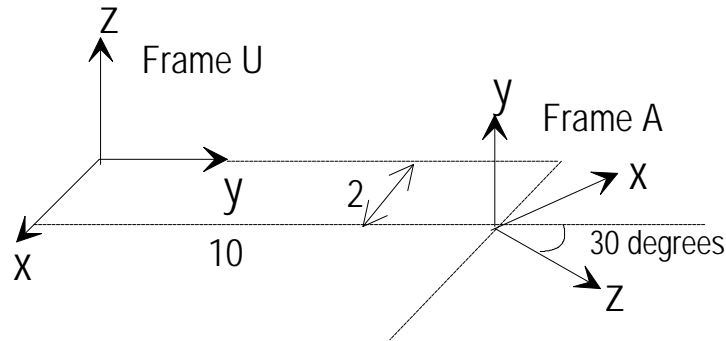

Figure 1

(10 marks)

- (b) A rigid body has Cartesian Frames A and B rigidly attached to it. Let  ${}^A\mathbf{T}_B$  describe the relative position and orientation between Frames A and B. Let Frames U and C be fixed to the universe with their relative position and orientation given by  ${}^U\mathbf{T}_C$ . The initial position and orientation of the rigid body is given by  ${}^U\mathbf{T}_A$ . The rigid body undergoes the following ordered sequence of motions:
- 1) rotation about the Z axis of Frame A by  $30^\circ$ ,
  - 2) rotation about the Y axis of Frame C by  $20^\circ$
  - 3) translation along the X, Y, and Z axes of Frame B by 1, 2, and 3 m, respectively.

Derive an expression for the new position and orientation of Frame A in Frame U,  ${}^U\mathbf{T}_A$ . (Express your answer in terms of  $4 \times 4$  matrix products. You need not simplify your answer.)

(15 marks)

- Q.2 (a) Figure 2a shows the position and orientation of two adjacent joint axes  $z_2$  and  $z_3$ . The assignment of the other axes of Frame 2 has been completed as shown in Figure 2. Complete the frame assignments for Frame 3 by indicating the position and orientation of the axes  $x_3$  and  $y_3$  according to the Denavit-Hartenberg convention given in class (according to the textbook by Fu, Lee and Gonzalez). Derive the four kinematic parameters  $q_3$ ,  $r_3$ ,  $d_3$ , and  $a_3$  that relate Frame 3 from Frame 2.

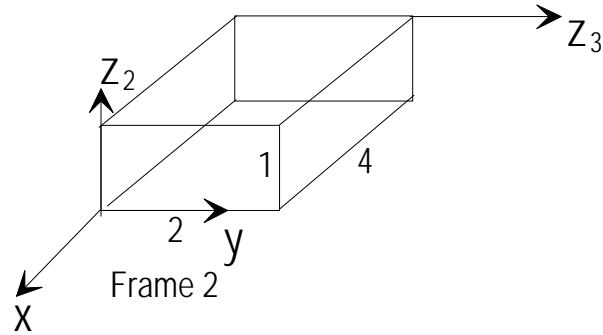

Figure 2a

(8 marks)

- (b) A robot has a translational joint followed by a rotational joint as shown in Figure 2b. The translational joint axis is along  $z_u$  and the rotational joint axis is parallel to  $x_u$  and connects links 1 and 2 at joint  $J_2$ . The positive direction of motion for joints 1 and 2 are along the positive  $z_u$  direction (vertically upwards), and counter-clockwise, respectively. Link 2 has a payload of 10 kg rigidly attached to its end.
- i) Each joint of the robot is moving. At the instant of time when joints 1 and 2 are at a configuration shown in Figure 2b, the velocities of joints 1 and 2 are 0.5 m/s and 1 rad/s, respectively. Determine the translational velocity of the centre of the payload (end-point of link 2) and the angular velocities of the payload, link 1 and link 2. Express these velocities as 3 D vectors in Frame U.
- (9 marks)
- ii) Determine the force and torque required in joints 1 and 2, respectively, to maintain the robot in equilibrium at the configuration shown in Figure 2b. Assume that the masses of the links and joints are negligible.

(8 marks)

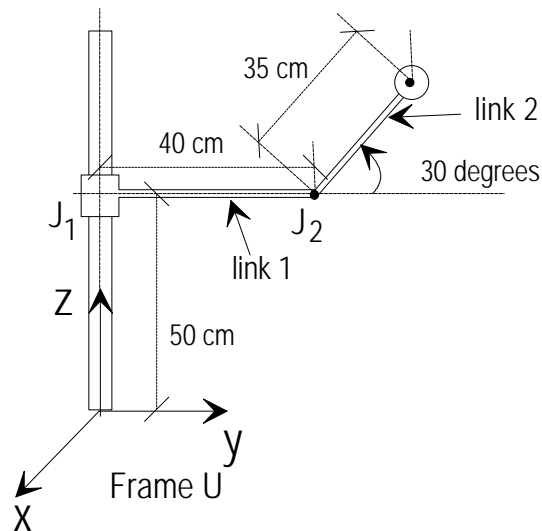

Figure 2b

- Q.3 (a) Figure 3 shows a two-link (PR) planar robot in the vertical plane. Let  $m_i$ ,  $i = 1, 2$ , be the lumped equivalent mass of link  $i$ ,  $d$  be the translational displacement of link 1,  $q$  be the angular displacement of link 2,  $l$  be the length of link 2,  $f_1$  be the external force on link 1 in the direction of  $d$ , and  $\tau_2$  be the torque to drive link 2.

- (i) What are the joint variables in the figure? (2 marks)
- (ii) Derive the dynamic equations using any method you are comfortable with. (13 marks)

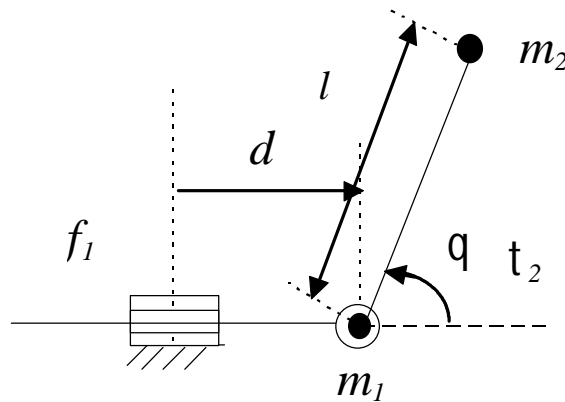

Figure 3: A PR robot in the vertical plane

- (b) What is the meaning of the generalised coordinates for a robot arm? (2 marks)
- (c) Give another different set of generalised coordinates for the robot shown in Figure 3. (2 marks)
- (d) Determine the state equations using the states  $x_1 = d$ ,  $x_2 = q$ ,  $x_3 = \dot{d}$ ,  $x_4 = \dot{q}$ . (6 marks)

- Q.4 (a) List, at least, three problems relating to workspace and singularities in Cartesian paths, and briefly explain. (5 marks)
- (b) Consider a system described by the following dynamic equations:

$$(m_1 + 2m_2 \cos q_2) \ddot{q}_1 + (m_3 + m_2 \cos q_2) \ddot{q}_2 - m_2 \sin q_2 \dot{q}_1 \dot{q}_2 - m_2 \sin q_2 (\dot{q}_1 + \dot{q}_2) \dot{q}_2 = t_1$$

$$(m_3 + m_2 \cos q_2) \ddot{q}_1 + m_4 \ddot{q}_2 - m_2 \sin q_2 \dot{q}_1^2 = t_2$$

where  $m_i$ ,  $i = 1, 2, 3, 4$ , are constants, and  $q_i$  and  $t_i$  are the generalised coordinates and generalised forces/torques for  $i = 1, 2$ .

- (i) Determine the inertia matrix, the coriolis force and centrifugal force vector, the gravitational force vector, and the generalised external force vector. (5 marks)

- (ii) Describe briefly the computed torque control technique for the robot described by the above equations. (10 marks)

- (iii) Briefly discuss the advantages and disadvantages of the computed torque method. (5 marks)

**(END of PAPER)**